



**USE AND MAINTENANCE**



**INDUSTRIAL ENGINES**

**8000**  
**SERIES**  
**EPA certified**

**IVECO**  
**MOTORS**

Iveco SpA  
PowerTrain  
Publication edited by  
Marketing - Adv. & Promotion  
Print L31022020 - 10/99

## GB

Thank you for preferring Iveco Motors and may we compliment you on the choice you have made.

Before carrying out any work on the engine, read through the procedures set out in this manual carefully.

If you follow these instructions your engine will be guaranteed trouble-free operation and a long life.

Remember that, wherever you are, the Iveco Motors Service Network will be at your side to offer you highest levels of skill and professionalism.

### Guarantee

In order to get the best performance from your engine and benefit from the guarantee you must comply with the instructions contained in this publication.

Failure to carry out these operations correctly or not at all may invalidate the guarantee.

### Spare parts

It is essential to use only Original Iveco Motors Spare Parts if the engine is to be kept in its original sound condition.

The use of non-original spare parts will invalidate the guarantee and release Iveco Motors from any long-term liability.

### Liability

The manufacturer's liability is dependent on the execution of the "Checks and maintenance" operations mentioned in this manual.

For this purpose, a record must be kept of the maintenance opera-

tions carried out, which, as far as extraordinary maintenance is concerned, must be performed by authorised workshops.

### Warning

The contents of this manual refer to the engine only; in particular, illustrations are approximate and some instructions are described in a purely functional manner, to permit the operations to be carried out on the engine.

The ways of executing the above instructions depend on the configuration of the controls and/or accessories of the machine on which the engine is installed and reference is made to the machine manual.

The information contained in this manual is correct at the time of publication.

The Manufacturer reserves the right to make amendments without prior notice at any time for reasons of a technical or commercial nature as well as to comply with legal requirements in different countries. It declines any liability for any errors or omissions.

---

## CALIFORNIA

### Proposition 65 Warning

Diesel engine exhaust and some of its constituents are known to the State of California to cause cancer, birth defects, and other reproductive harm.

---

Please note this warning and remember:

- Always start and operate the engine in a well-ventilated area;
- If in an enclosed area, vent the exhaust to the outside;
- Do not modify or tamper with the exhaust system.

## LIST OF CONTENTS

	<b>Page</b>		
General information .....	1	Starting with electronic governor .....	33
Safety requirements .....	3	Stopping the engine .....	33
Warning labels .....	4	Precautions for normal engine operation .....	34
Maintenance operations .....	5	Checks and maintenance .....	34
Engine identification data.....	5	Engine fault diagnosis .....	34
<b>Industrial engines</b>		Maintenance when engine is out of commission	
Engine views .....	7	for long periods .....	37
Engine data .....	12	Main regulation and repair data .....	38
Before starting .....	12	Capacities .....	39
Starting industrial engines.....	13	Engine handling .....	41
Stopping the engine .....	14	Disposal of used parts.....	41
Water pre-heating .....	14	What to do in an emergency .....	42
Precautions for normal engine operation.....	15		
Running in .....	16		
Checks and maintenance.....	17		
Routine checks .....	19		
Routine maintenance.....	23		
<b>Engines for generating units</b>			
Engine views .....	24		
Engine data .....	31		
General .....	32		

## **SAFETY REQUIREMENTS**

### **Basic rules**

The following recommendations are given so as to reduce the risk to persons and property when an engine is in service or out of service. Engines must not be used for applications other than those declared by the manufacturer.

Incorrect handling, modifications and use of non-original parts may affect safety.

When handling the engine, take care to use suitable equipment to be applied to the points specially provided on the engine (see paragraph "Handling engine").

This publication refers to the engine component; the machine on which it is installed must meet the specific safety requirements.

## WARNING LABELS

Warning labels are applied to the engine by the machine's builder. Their meanings are given below.

**N. B.** Labels which show an exclamation mark indicate that there is a possibility of danger.



Lift point for engine only.



Fuel filler indication on tank  
(where present).

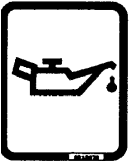

Lubricating oil filler indication.

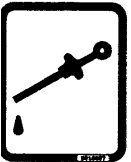

Oil dipstick indication.



**Danger of burns:**  
**Expulsion of pressurised hot water.**



**Danger of burns:**  
**Hot parts indication.**



**Risk of fire:**  
**Due to presence of fuel.**

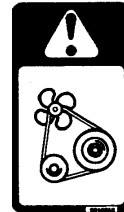

**Risk of entangling and cutting:**  
**Indication of rotating parts**  
**(pulleys, belts, fan).**

## MAINTENANCE OPERATIONS

For the purposes of safety it is important that the maintenance operations indicated in this manual are carried out according to the following guidelines:

- **checks**, can be carried out both by the workshop and the machine user;
- **routine maintenance checks**, marked by the spanner symbol (see diagram below), must be carried out by qualified persons using the appropriate equipment and protections;
- **non-routine maintenance operations**, given their particular nature, must be carried out by authorised workshops which are equipped with the appropriate tools and are in possession of the proper technical information.

"*Authorised workshops*" are those workshops belonging to the Iveco Motors service organisation and those belonging to the machine manufacturer's service organisation if authorised by Iveco Motors.



## ENGINE IDENTIFICATION DATA

The engine is identified by a label, fitted on the rocker cover.

According to 40CFR part 89, the label reports some important pieces of information; the most significant ones are the following:

- Engine family name (position "A")
- Engine model (position "B")
- Model year (position "C")

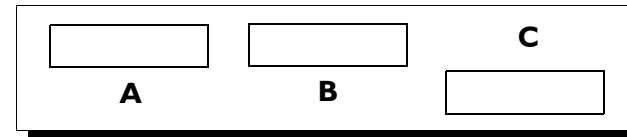

For commercial reasons, the engine is also identified by a Commercial Code which is linked to the Engine Family name and the Engine Model according to the following table:

Engine* Family Name	Engine Model	Commercial Code
<u>W</u> VEXL05.9 DAR	8035.05.562	8035U06.05
<u>W</u> VEXL05.9 DAR	8035.05.550	8035U00.00
<u>W</u> VEXL05.9 DAR	8045.05.562	8045U06.55
<u>W</u> VEXL05.9 DAR	8045.05.550	8045U00.00
<u>W</u> VEXL05.9 DAR	8045.05.551	8045U00.50
<u>W</u> VEXL05.9 DAS	8045.25.550	8045SU00.00
<u>W</u> VEXL05.9 DAS	8045.25.551	8045SU00.50
<u>W</u> VEXL05.9 DAR	8065.05.562	8065U06.05
<u>W</u> VEXL05.9 DAR	8065.05.560	8065U00.00
<u>W</u> VEXL05.9 DAS	8065.25.562	8065SU07.05
<u>W</u> VEXL05.9 DAS	8065.25.561	8065SU00.00
<u>W</u> VEXL05.9 GST	8061.25.462	8061SRU26.05
<u>W</u> VEXL05.9 GST	8065.25.461	8065SRU26.04

\* Please note that the first digit of the Engine Family Name changes according to the Model Year as per the following list:

1998 W  
1999 X  
2000 Y  
2001 I  
2002 2  
2003 3  
2004 4

## INDUSTRIAL ENGINES

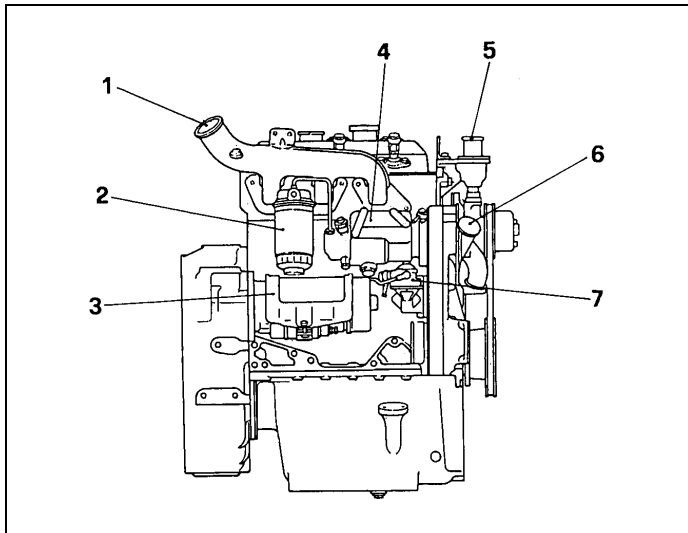

**Engine 8035U00: right side view**

1. Intake manifold - 2. Fuel filter - 3. Starter motor - 4. Injection pump - 5. Thermostat housing - 6. Oil filler cap - 7. Fuel pump.

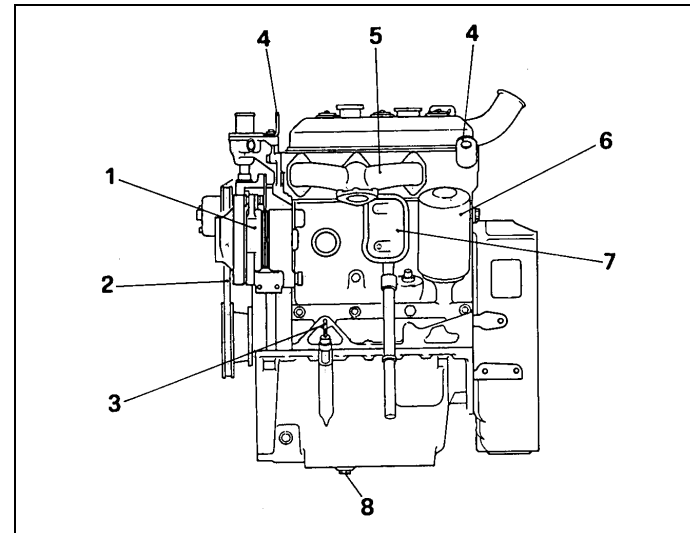

**Engine 8035U00: left side view**

1. Alternator - 2. Water pump-alternator drive belt - 3. Oil dipstick - 4. Engine lift eyes - 5. Exhaust manifold - 6. Oil filter - 7. Oil vapour breather - 8. Oil drain plug.



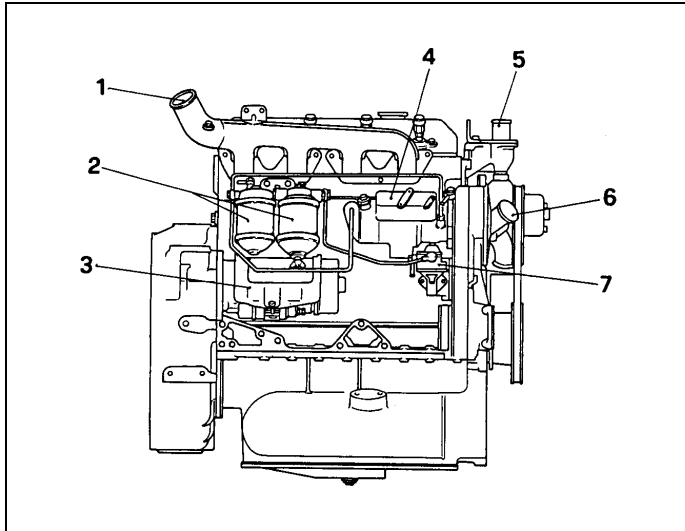

**Engine 8045U00: right side view**

1. Intake manifold - 2. Fuel filters - 3. Starter motor - 4. Injection pump - 5. Thermostat housing - 6. Oil filler cap - 7. Fuel pump.

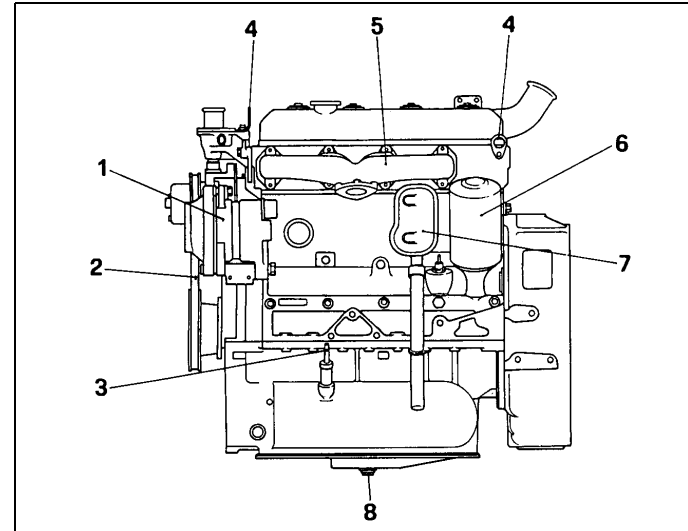

**Engine 8045U00: left side view**

1. Alternator - 2. Water pump-alternator drive belt - 3. Oil dipstick - 4. Engine lift eyes - 5. Exhaust manifold - 6. Oil filter - 7. Oil vapour breather - 8. Oil drain plug.

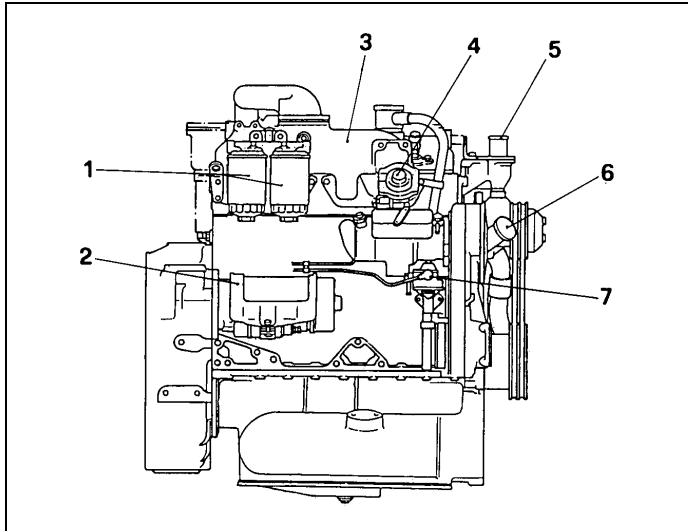

**Engine 8045SU00: right side view**

1. Fuel filters - 2. Starter motor - 3. Intake manifold - 4. Injection pump - 5. Thermostat housing - 6. Oil filler cap - 7. Fuel pump.

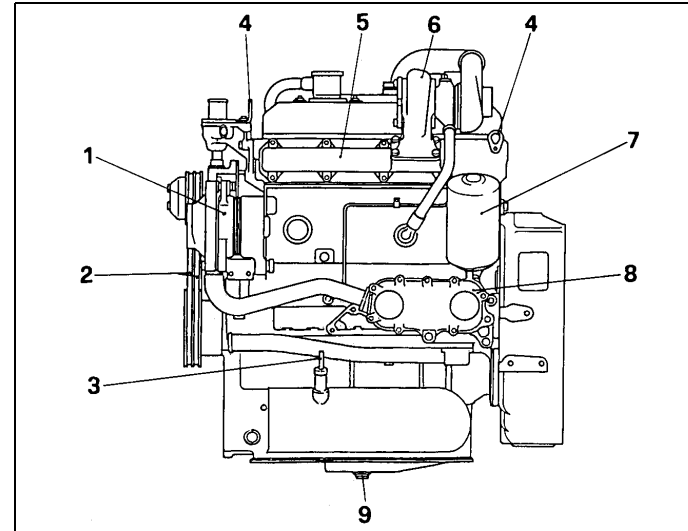

**Engine 8045SU00: left side view**

1. Alternator - 2. Water pump-alternator drive belts - 3. Oil dipstick - 4. Engine lift eye - 5. Exhaust manifold - 6. Turbocharger - 7. Oil filter - 8. Oil-water heat exchanger - 9. Oil drain plug.

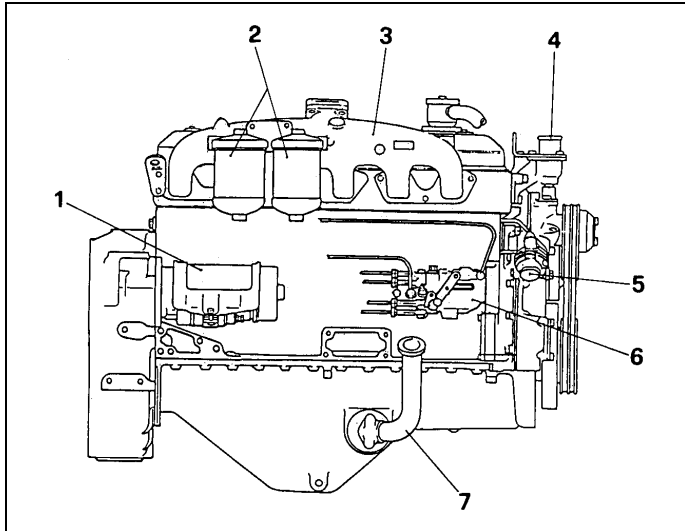

**Engine 8065U00: right side view**

1. Starter motor - 2. Fuel filters - 3. Intake manifold - 4. Thermostat housing - 5. Fuel pump - 6. Injection pump - 7. Oil filler cap/dipstick.

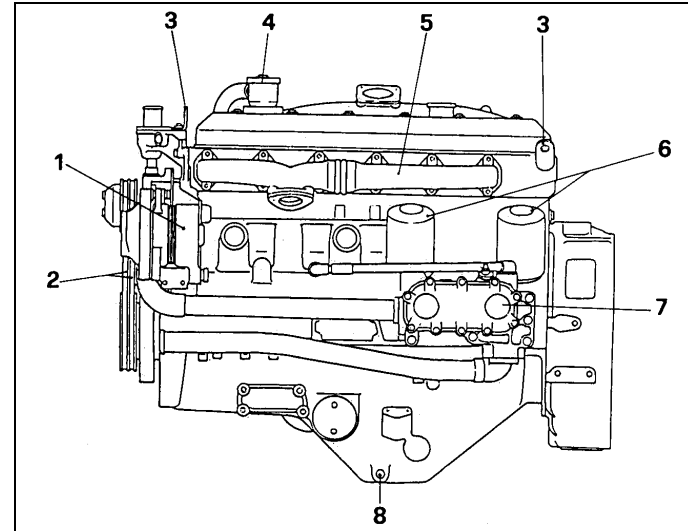

**Engine 8065U00: left side view**

1. Alternator - 2. Water pump-alternator drive belts - 3. Engine lift eyes - 4. Oil vapour breather - 5. Exhaust manifold - 6. Oil filters - 7. Oil-water heat exchanger - 8. Oil drain plug.

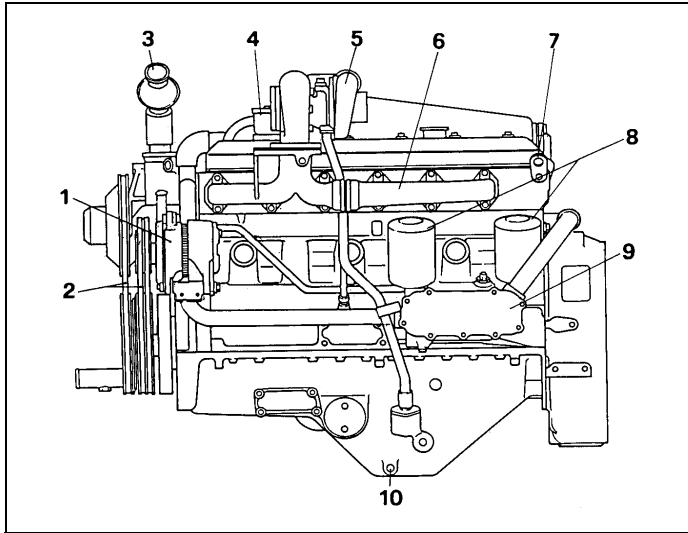

**Engine 8065SU00: right side view**

1. Starter motor - 2. Fuel filters - 3. Intake manifold - 4. Thermostat housing - 5. Fuel pump - 6. Injection pump - 7. Oil filler cap/dipstick.

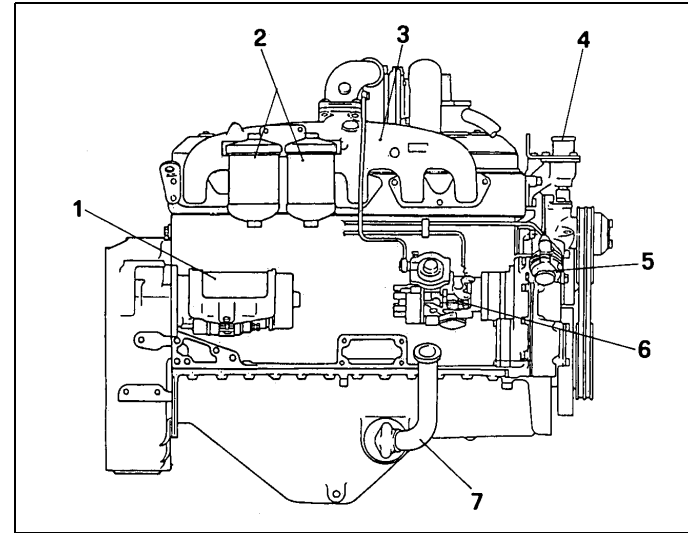

**Engine 8065SU00: left side view**

1. Alternator - 2. Water pump-alternator drive belts - 3. Engine lift eyes - 4. Oil vapour breather - 5. Turbocharger - 6. Exhaust manifold - 7. Oil filters - 8. Oil-water heat exchanger - 9. Oil drain plug.

## GENERAL ENGINE DATA

- Diesel cycle, 4-stroke, injection ..... direct
- cylinders, number and layout (models 8035) ..... 3, in line
- cylinders, number and layout (models 8045) ..... 4, in line
- cylinders, number and layout (models 8065) ..... 6, in line
- bore and stroke..... 104 x 115mm
- total capacity (models 8035) ..... 2.9 l
- total capacity (models 8045) ..... 3.9 l
- total capacity (models 8065) ..... 5.9 l
- direction of rotation (seen from flywheel side)..... anti-clockwise

## SPECIFIC INDUSTRIAL ENGINE DATA

Description	8035	8045	8045	8065	8065
	U00	U00	SU00	U00	SU00
- Injection pump type	Rotary	Rotary	Rotary	Rotary	Rotary
- Intake	NA	NA	TC	NA	TC
- Maximum output (*)					
(hp)	58	79	106	108.5	158
- At speed of rpm	2500	2500	2300	2500	2300
- Dry weight kg	335	415	400	490	500

(\*) Gross rating without fan (ISO Fuel Stop Power): - after 50 hours running - 3% tolerance - net calorific value of the fuel: 42,840 kJ/kg (10,200 kcal/kg) - ambient reference conditions: ISO 3046/I; 25°C; 100 kPa; 30% relative humidity - emissions according to 8 mode cycles, ISO 8178 and EPA and CARB limits.



### WARNING

*It is absolutely forbidden, at risk of invalidating the guarantee and the liability of Iveco Motors, to change the above characteristics, and in particular to change the adjustment of the injection pump and, where fitted, the waste-gate valve.*

## BEFORE STARTING

Every day, before starting the engine:

- check the fluid levels (fuel, engine oil and coolant).
- check that the air intake cleaner is not clogged, checking that the mechanical indicator on the cleaner is not showing "red".

If the cleaner is clogged, clean it following the instructions set out in the paragraph "Routine checks and maintenance".

**N.B.** When an electric indicator is fitted (optional) a warning light on the control panel will light up immediately; in this case the cleaner must be cleaned straightaway.



### Attention!

*Before starting the engine, check that the environment in which you are to work is suitable for the mixture of harmful exhaust gases. Also check that combustible fuel gases such as hydrocarbons are not present in the ambient air.*

## STARTING INDUSTRIAL ENGINES

**Engines** - with distributor injection pump - fitted with Iveco Motors instrument panel (optional)

### WITH COLD ENGINE

- 1) Bring the accelerator lever to 1/2 of its maximum travel
- 2) Turn the key from position "A" to position "B". The alarm indicators and buzzer are activated for about 2 seconds

If an air pre-heating system is fitted:

- 3) Turn the key from position "B" to position "C", keeping it there for about 20 seconds;
- 4) Press the key right in and turn to position "D", until the engine starts. If the engine does not start reset the key to position "A" and repeat the operation from point 3;
- 5) Once the engine has started, operate the accelerator straightaway, bringing the lever to a position where engine speed is just above minimum.

### WITH WARM ENGINE

- 1) Hold the accelerator lever at minimum
- 2) Turn the key from position "B" to position "D" and release it as soon as the engine starts.

*ATTENTION: Indicator "7D" showing pre-heating completed is not connected.*

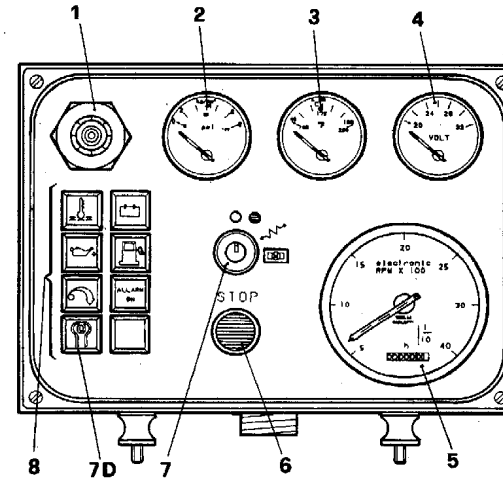

1. Buzzer
2. Oil gauge
3. Water temperature gauge
4. Voltmeter
5. Rev counter/hourmeter
6. Engine stop button
7. Starter/stop switch
8. Alarm indicators

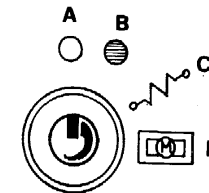

## **ENGINES WITHOUT IVECO INSTRUMENT PANEL**

If the engines are not fitted with an Iveco Motors instrument panel, the starting instructions given previously may vary according to the type of control panel fitted to the machine on which the engine is installed (see the instructions supplied by the machine's manufacturer).

## **GENERAL GUIDELINES FOR STARTING (valid for all engines)**

Release the starter control as soon as the engine starts so as not to damage the engine and starter motor.

Remember that it is not efficient, in terms of reaching the operating temperatures, to keep the engine idling.

After about 1 minute start to use the engine but avoid using it at high output.

## **STOPPING THE ENGINE**

1. Before stopping the engine, let it idle for a few minutes with no load; this allows a uniform reduction in the water and oil temperature, avoiding serious damage to the engine caused by thermal shock.

2. The engine is stopped as follows:

- de-energise the stop solenoid incorporated in the pump.
- operate the stop lever (mechanically or electrically).

If the engines are fitted with Iveco Motors instrument panels (optional), the engine is stopped by pressing the stop button (6) or by turning the starter key to "A".

## **WATER PRE-HEATING (ELECTRIC 220 V, SINGLE-PHASE - OPTIONAL)**

This device, supplied on request, is provided to aid starting at low temperatures or in circumstances where an immediate supply of power is required. It incorporates a thermostat which cuts off the supply when the set temperature is reached.



### **WARNING!**

*Always check that the equipment is properly earthed.*

## PRECAUTION FOR NORMAL OPERATION OF THE ENGINE

- Increasing engine speed from idling to full speed and viceversa must be achieved gradually in order to ensure perfect combustion and trouble-free operation of all the engine components.
- The speed/power values in engine use must conform to the specifications given in the technical/commercial documentation.
- During engine operation, monitor the following points:

**Engine cooling system** - Check that the water temperature is kept within the maximum permitted values as specified in the table "Main regulation and repair data". If the water temperature is excessive, check the cause consulting the table "Engine fault diagnosis". When topping up the engine coolant, follow the instructions given in the paragraph "Checks and maintenance".



### Attention!

*Never open the water filler plug when the engine is hot. The cooling system is pressurised and the hot liquid will be expelled violently if the pressure is released too violently, causing burns.*

**Lubrication system** - Check that the oil pressure, with the engine hot and operating at normal speed, falls within the limits indicated in the table "Main regulation and repair data". If the oil pressure does not correspond to the values indicated check the cause for this

by consulting the table "Engine fault diagnosis". When topping up the oil in the lubrication system, follow the instructions given in the paragraph "Checks and maintenance".

**Fuel system** - Avoid working with the fuel tank at minimum reserve levels so as to prevent the formation of condensation and failure of the system due to intake of air, which causes the engine to stop.



### Attention!

*When filling up with fuel be particularly careful that the solid or liquid pollutants do not enter the tank with the fuel. Do not smoke or use naked flames.*

**Intake and exhaust system** - Check regularly that the air intake system is clean. The maintenance intervals change according to the working conditions. In particularly dusty environments more regular cleaning is required; follow the instructions set out in the paragraph "Checks and maintenance".



### Attention!

*Visually inspect that the exhaust system is not blocked or damaged so as to prevent dangerous fumes.*



**Electrical starter system** - Check the battery state of charge regularly, particularly during the winter months.  
When topping up the electrolyte level in the batteries, follow the instructions set out in the paragraph "Checks and maintenance".



**Attention!**

*Do not smoke or bring naked flames in the vicinity of the batteries to avoid explosions.*

**RUNNING IN (50 HOURS)**

Avoid using the engine for long periods, at high output.  
After the running-in period remember to carry out the operations indicated in the paragraph "Checks and maintenance".

## CHECKS AND MAINTENANCE

### INTRODUCTION

The **checks** indicated in this section can be carried out either by the workshop or by the machine user.

The **routine maintenance operations**, identified by the key symbol, must be carried out by qualified personnel who have the appropriate equipment and protections.

The **non-routine maintenance operations** identified by the spanner symbol, given their particular nature, must be carried out by authorised workshops equipped with appropriate equipment and with the proper technical information.

### DURING MAINTENANCE

- Never wear loose clothing, rings, bracelets and/or chains when working next to engines or moving parts.
  - Use protective gloves and goggles:
    - . when topping up batteries with acid
    - . when topping up with inhibitors or anti-freeze
    - . when changing or topping up the lubricating oil (hot engine oil can cause burns when it is drained. Let it cool down to under 50°C).
- Use goggles if compressed air is used (in this case the maximum pressure of the air, used for cleaning, must be under 2 Atm (30 psi, 2 kg/cm<sup>2</sup>).

- Use the protective helmet if working in an area with suspended loads or with installations at head height.
- Always wear safety shoes and overalls.
- Use protective cream for the hands.
- Always change out of wet overalls.



#### Attention!

*Avoid carrying out maintenance when there is live voltage; always check that the equipment is properly earthed. During regulation operations make sure that you have dry hands and feet and use insulating platforms.*

- Never carry out repairs with which you are unfamiliar. Always follow the instructions and, if these are not available, contact the supplier or qualified personnel as described above.
- Always keep the engine clean, eliminating oil, diesel and/or coolant stains.
- Place dirty rags inside flameproof containers.
- Do not leave rags on the engine.
- Use suitable secure containers for used oil.
- When you start an engine after a repair, take steps to stop the intake of air in case of over-rewinding on starting.

## CHECKS

### Regularity

Check oil level in sump .....	daily
Check water level in radiator (1).....	daily
Check air cleaner for clogging (1).....	daily
Check radiator/intercooler for restriction (1) .....	daily
Check electrolyte level in batteries (1) (2) .....	every 300 hours



## ROUTINE MAINTENANCE

### Regularity

Change engine oil (2)(4)(5) _____	300 hours
Change oil filters (2)(4) _____	300 hours
Change fuel filter (2) _____	300 hours (3)
Clean fuel pump filter (2) _____	300 hours (3)
Adjust drive belt tension (2) _____	300 hours
Adjust valve clearance _____	900 hours
Calibrate injectors and possible nozzles replacement (as service items) _____	900 hours



## NON-ROUTINE MAINTENANCE

During its life the engine will also require certain specialist operations to be carried out, such as: valve seat dressing, turbocharger and heat exchanger cleaning, injection pump, water pump and electrical system overhaul.

Consult the Iveco Motors Service Network which is available to give you advice and carry out the above operations promptly using fully trained and professional personnel to ensure that the engine has a long and efficient life.

Replace crankshaft damper (1):

- engines 8045SU00 \_\_\_\_\_ 10,000 hours (6)
- engines 8065U00 \_\_\_\_\_ 9,000 hours (6)
- engines 8065SU00 \_\_\_\_\_ 6,000 hours (6)

(1) The regularity of these operations can vary depending on engine use and the ambient conditions in which it operates.

(2) These operations must be carried out annually even when the specified operating hours have not been reached.

(3) Maximum period, with high-quality fuel; it may vary depending on fuel contamination.

(4) Change after the first 50 hours of service (running-in).

(5) If fuel with a sulphur content of more than 0.5% is used, the engine oil change intervals must be halved.

(6) Whenever the engine is subject to a general overhaul.

## ROUTINE CHECKS

### ENGINE OIL LEVEL CHECK

Carry out the check with the engine off, cold and with the machine on the level.

Check that the oil level falls between the "Min" and "Max" limits etched on the dipstick. If necessary, top up through the oil filler, after turning the cap anti-clockwise.



#### WARNING

*The level must never exceed the "Max" mark etched on the dipstick. After the check, reposition the dipstick correctly and fully tighten the filler cap, turning it clockwise as far as it will go.*

### RADIATOR WATER LEVEL CHECK

Carry out the check with the engine off and cold.

Remove the radiator water filler cap by turning it anti-clockwise and inspect the water level.

The level must never exceed two thirds of the height of the reservoir to allow for an increase in volume when the engine is hot.

If necessary, top up bearing in mind that overfilling may, during engine operation, result in excess water being expelled from the drain pipe or pressure relief valve.

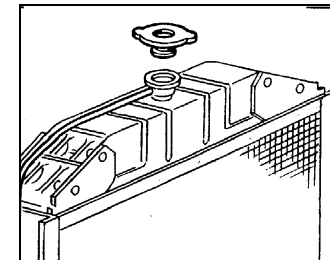
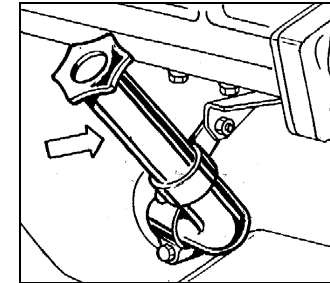
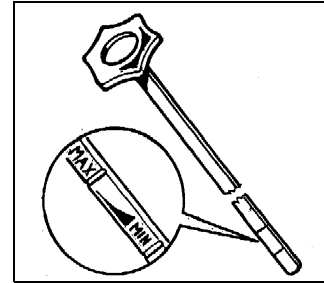

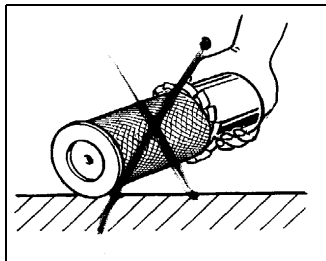
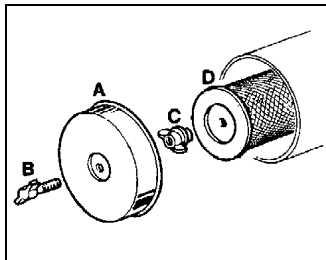
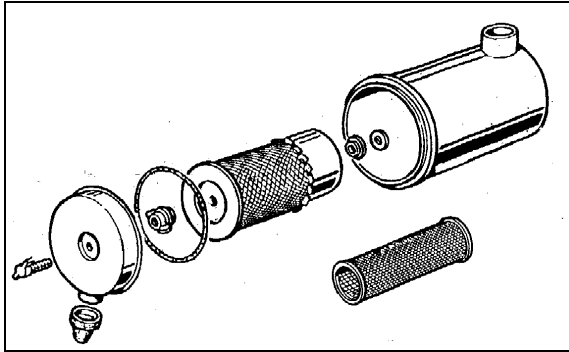

To top up, use a mix of clean water and anti-freeze/corrosion inhibitor of the type described in the "Capacities" table.

During the winter months, check that there is the correct percentage of anti-freeze to prevent the engine being damaged by ice.

Different water level check procedures may be required depending on the various cooling system configurations of the machine on which the engine is installed.



**Attention!**

*Never open the water filler cap when the engine is hot. The cooling system is pressurised and the hot fluid will spurt out if the pressure is released too quickly, causing burns.*

**AIR CLEANER CONDITION CHECK**

As previously indicated in the paragraph "Before starting", if the air cleaner requires cleaning, proceed as follows:

- stop the engine and leave to cool
- lift the cleaner cover A turning the wing nut B anti-clockwise
- turn the retaining nut D anti-clockwise and take out the external cartridge C, making sure that no dust gets into the hose.

Pay attention to the following advice when working on the cartridge:

- never strike the cartridge with tools
- clean the cartridge with dry compressed air working from the inside outwards from the inside (the pressure must not exceed 2 bar so as not to damage the cartridge);
- check the condition of the cartridge before removing it, using a lamp to light up the inside;

Change the cartridge if it has any tears or holes;  
- check that the seal on the base of the cartridge is in good condition.

Some air cleaners are fitted with a safety cartridge (optional); this cartridge (E) must never be cleaned but changed every 3 changes of the external cartridge.

To refit, reverse the dismantling operations, checking that the cartridge is housed correctly in its seat.

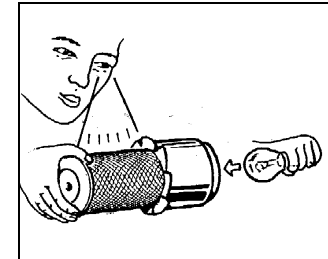
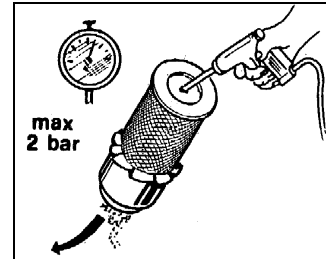

**WARNING**

*If the cartridge is not properly fitted, unfiltered air could enter the engine and cause serious damage.*

*Where possible, have the above operations carried out by qualified personnel. After the work on the cartridge has been completed, the mechanical clogging indicator (see figure opposite) must be put back into service by pressing the special button located at the top of the indicator.*

*The electrical indicator does not require this operation.*

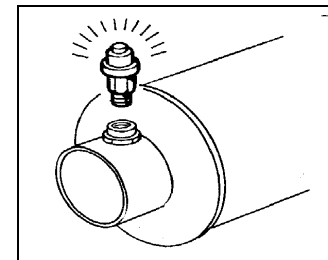
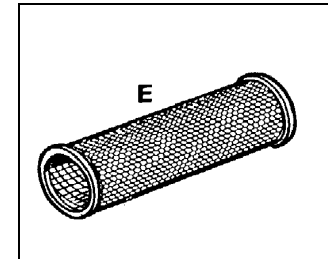

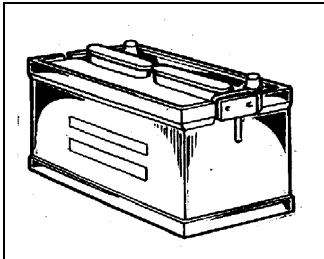
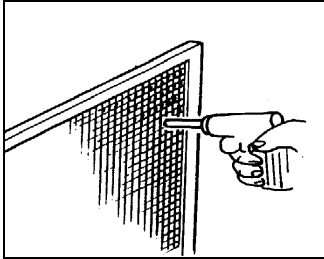

### **RADIATOR RESTRICTION CHECK**

Check that the air input surfaces in the radiators are free of dirt (dust, mud, straw etc.) and clean them straightaway using compressed air/steam.

The use of these cleaning methods means that suitable protection must be worn on the hands, face and eyes.

### **BATTERY ELECTROLYTE LEVEL CHECK**

With the batteries out of service and cold, check that the electrolyte level falls between the "Max" and "Min" limits; if the level is below the minimum, top up with distilled water.

During the summer months, check the level more frequently.

If the engine is unused, check the electrolyte monthly and, if the battery needs to be recharged, consult a specialist workshop.

Also check that the terminals and clamps are clean, tightened and protected with vaseline.



#### **Attention!**

*The batteries contain highly corrosive sulphuric acid; when topping up with distilled water wear protective gloves and goggles. Where possible, have the above operations carried out by qualified personnel.*

*Do not smoke or bring naked flames within the vicinity of the batteries to avoid explosions.*



## ROUTINE MAINTENANCE

Remember to have these operations carried out by specialist/authorised workshops, keeping to the specified intervals and bearing in mind that the intervals may change depending on engine use and the ambient conditions in which it operates.

### CHANGING SWITCHABLE FUEL FILTERS WITH ENGINE RUNNING (OPTIONAL)

Engines fitted with these filters are normally destined for continuous use and allow fuel filters to be changed whilst the engine is running. This operation must be carried out by workshop personnel, bearing in mind:

1. When the engine first starts, with switch lever vertical (0), bleed the two filters completely to ensure that complete fuelling can take place.
2. During the operation hold the lever in one of the two horizontal positions.
3. Before the routine filter replacement date (see "Routine Maintenance" table) switch over the circuit, turning the lever through 180. This cuts off fuel from the clogged filter.
4. Change the clogged filter.
5. Fit the new fuel filter after filling it with fuel.
6. Bleed the fuel system (point 1).

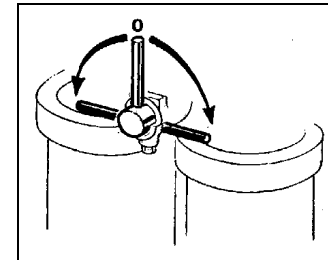
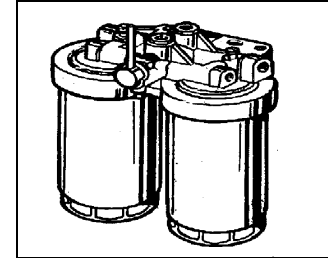



## ENGINES FOR GENERATING UNITS

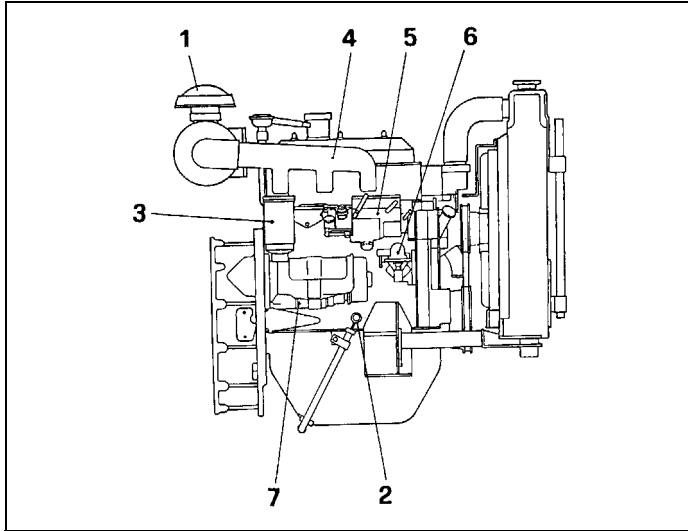

### Engines 8035U06: right side view

1. Air filter - 2. Oil dipstick - 3. Fuel filter - 4. Intake manifold - 5. Injection pump - 6. Fuel pump - 7. Starter motor.

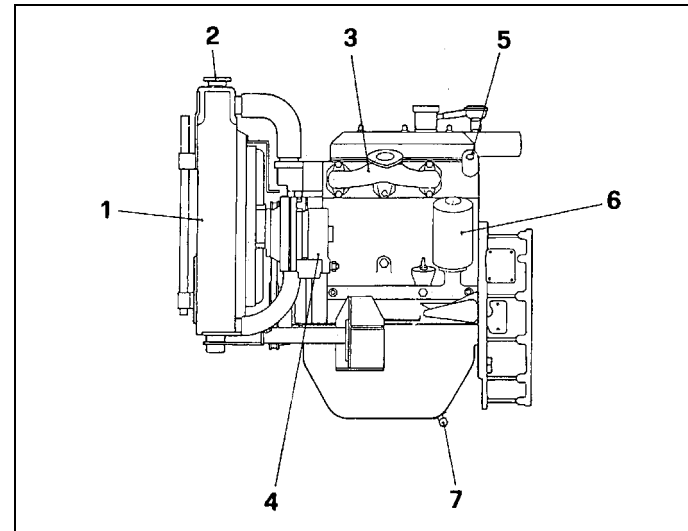

### Engines 8035U06: left side view

1. Water radiator - 2. Water feed cap - 3. Exhaust manifold - 4. Alternator - 5. Engine lift eye - 6. Oil filter - 7. Oil drain plug.

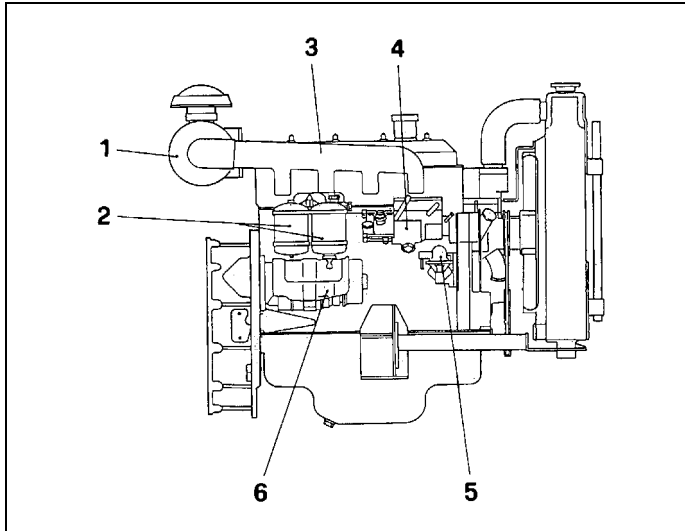

**Engines 8045U06: right side view**

1. Air filter - 2. Fuel filters - 3. Intake manifold - 4. Injection pump -  
5. Fuel pump - 6. Starter motor.

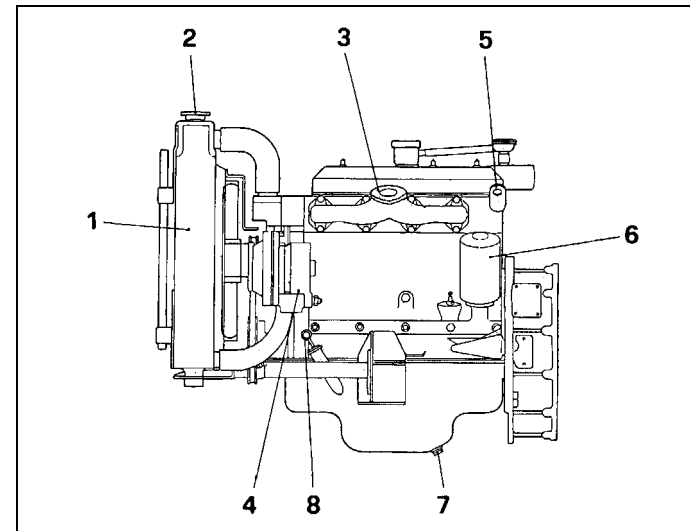

**Engines 8045U06: left side view**

1. Water radiator - 2. Water feed cap - 3. Exhaust manifold - 4. Al-  
ternator - 5. Engine lift eye - 6. Oil filter - 7. Oil drain plug - 8. Oil  
dipstick.

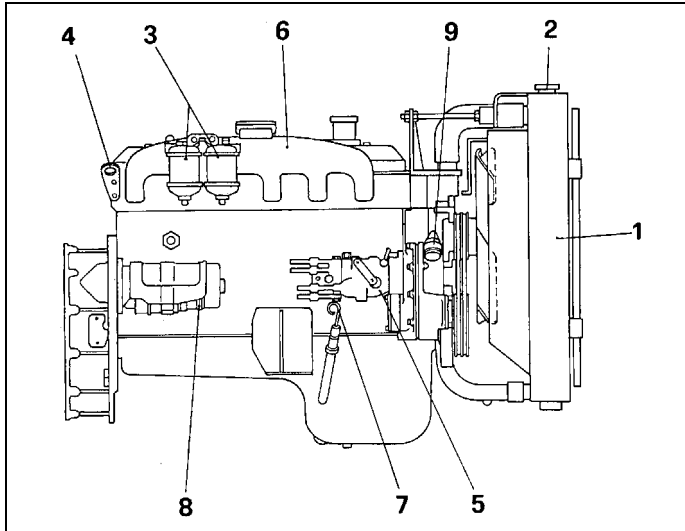

**Engines 8065U06: right side view**

1. Water radiator - 2. Water feed cap - 3. Fuel filters - 4. Engine lift eye - 5. Fuel pump - 6. Intake manifold - 7. Oil dipstick - 8. Starter motor - 9. Fuel pump.

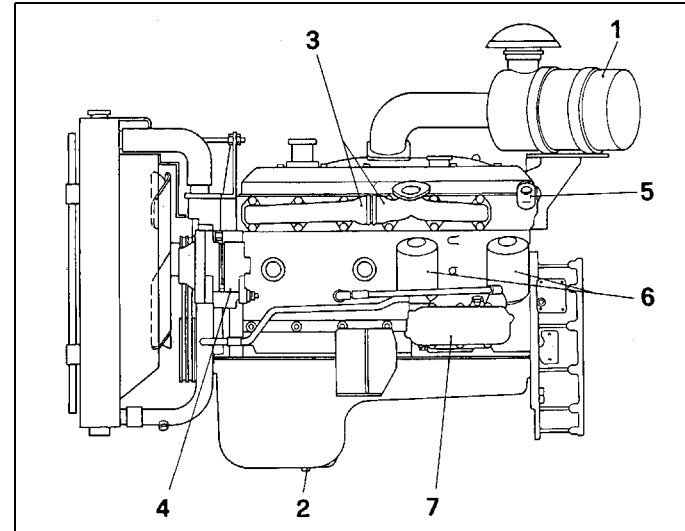

**Engines 8065U06: right side view**

1. Air filter - 2. Oil drain plug - 3. Exhaust manifold - 4. Alternator - 5. Engine lift eye - 6. Oil filters - 7. Oil-water heat-exchanger.

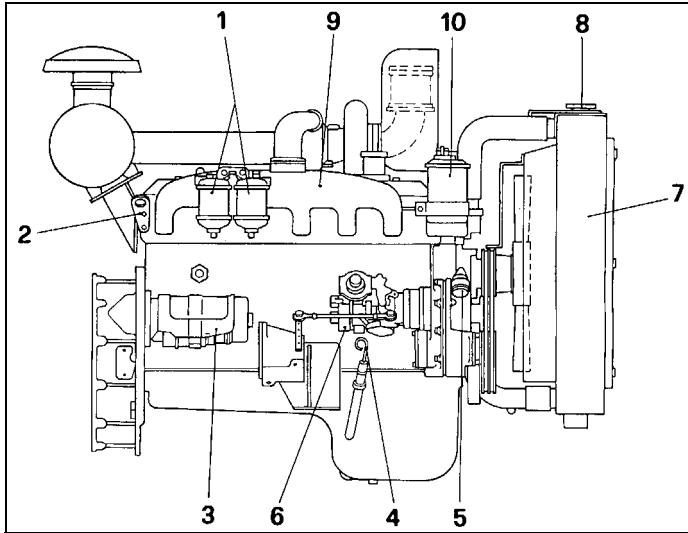

**Engines 8065SU07: right side view**

- 1. Fuel filters - 2. Engine lift eye - 3. Starter motor - 4. Oil dipstick -
- 5. Fuel pump - 6. Injection pump - 7. Radiator - 8. Water feed cap -
- 9. Intake manifold - 10. Engine oil breather

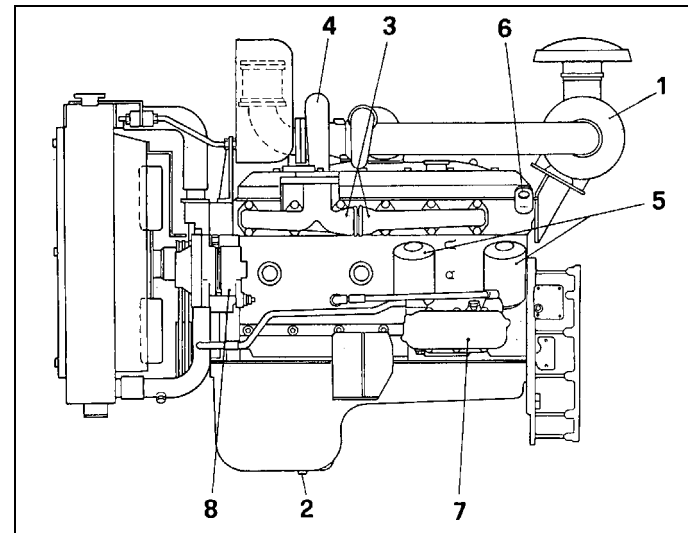

**Engines 8065SU07: left side view**

- 1. Air filter - 2. Oil drain plug - 3. Exhaust manifold - 4. Turbocharger -
- 5. Oil filters - 6. Engine lift eye - 7. Oil-water heat exchanger - 8.
- Alternator

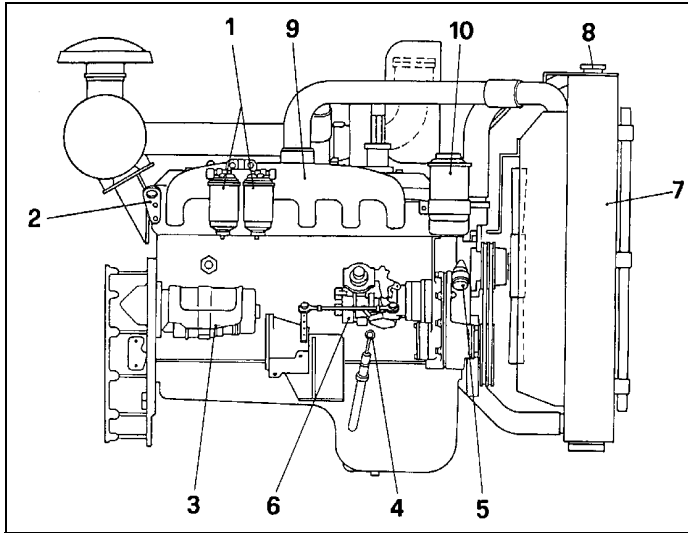

**Engines 806 ISRU26: right side view**

- 1. Fuel filters - 2. Engine lift eye - 3. Starter motor - 4. Oil dipstick -
- 5. Fuel pump - 6. Injection pump - 7. Radiator - 8. Water feed cap -
- 9. Intake manifold - 10. Engine oil breather

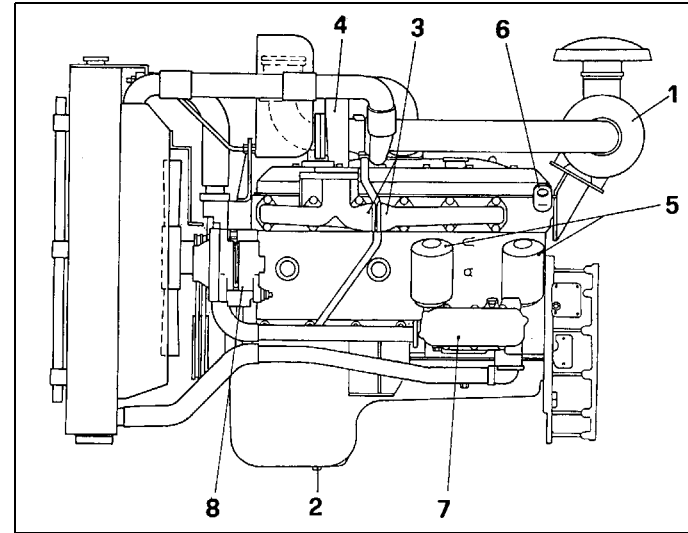

**Engines 806 ISRU26: left side view**

- 1. Air filter - 2. Oil drain plug - 3. Exhaust manifold - 4. Turbocharger -
- 5. Oil filters - 6. Engine lift eye - 7. Oil-water heat exchanger - 8.
- Alternator

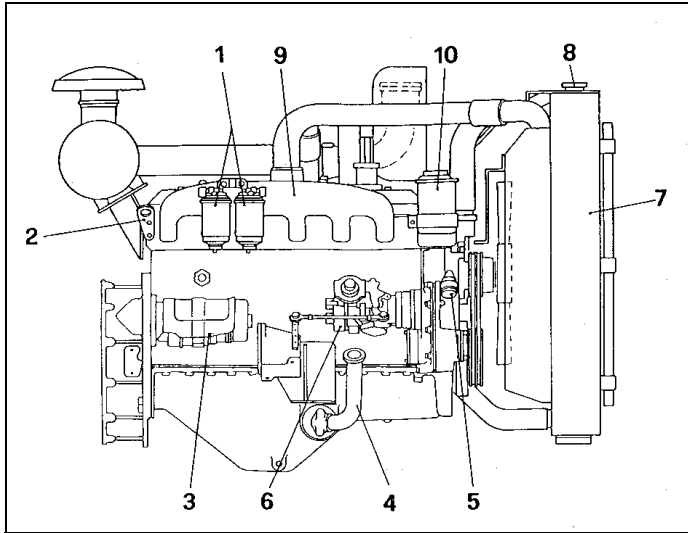

**Engines 8065SRU26: right side view**

- 1. Fuel filters - 2. Engine lift eye - 3. Starter motor - 4. Oil dipstick -
- 5. Fuel pump - 6. Injection pump - 7. Radiator - 8. Water feed cap -
- 9. Intake manifold - 10. Engine oil breather

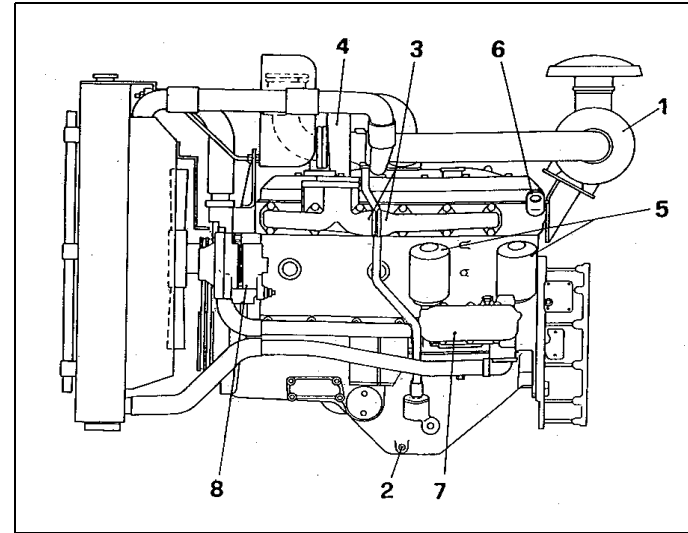

**Engines 8065SRU26: left side view**

- 1. Air filter - 2. Oil drain plug - 3. Exhaust manifold - 4. Turbocharger
- 5. Oil filters - 6. Engine lift eye - 7. Oil-water heat exchanger - 8.
- Alternator

## GENERAL ENGINE DATA

- Diesel 4-stroke, injection ..... direct
- cylinders, number and layout (models 8035) ..... 3, in-line
- cylinders, number and layout (models 8045) ..... 4, in-line
- cylinders, number and layout (models 8065/8061) ..... 6, in-line
- bore and stroke ..... 104 x 115mm
- total capacity (models 8035) ..... 2.9 l
- total capacity (models 8045) ..... 3.9 l
- total capacity (models 8065/8061) ..... 5.9 l
- engine direction of rotation  
(seen from flywheel side) ..... anti-clockwise

## SPECIFIC ENGINE DATA

Description	8035 U06	8045 U06	8065 U06	8065 SU07	8061 SRU26	8065 SRU26
- Injection pump type	Rotary	Rotary	Rotary	Rotary	Rotary	Rotary
- Speed governor	electronic	electronic	electronic	electronic	electronic	electronic
- Intake	NA	NA	NA	TC	TCA (I)	TCA (I)
- Net flywheel output: maximum standby power (fuel stop power) - ISO3046						
1800 rpm	34 KW	45 KW	67 KW	90 KW	126 KW	126 kW
- Dry weight	370 Kg	415 Kg	560 Kg	580 Kg	590 Kg	620 kg

(I) Air/Air intercooler



**WARNING**

*It is absolutely forbidden, at risk of invalidating the guarantee and liability of Iveco Motors, to change the above characteristics, and in particular to change the adjustment of the injection pump.*

**GENERAL**

The generating unit engine is derived from the industrial engine, the difference being its fixed speed operation (1500 or 1800 rpm).

For this purpose the injection pumps are fitted with an electronic governor.

The electronic governor can be isochronous: once the transient is exceeded, there may be no deviation between no-load and full-load.

Set out below are all the operating and maintenance instructions for generating unit engines that diverge from the instructions for industrial engine versions.



## STARTING WITH ELECTRONIC GOVERNOR

The engine can be started and brought to a calibration speed other than 1500 rpm or 1800 rpm, depending on the design characteristics of the control panel.



### **Attention!**

*If the engine is part of a generating unit with automatic start, starting can take place at any time. Therefore, for the purposes of safety, refer to the recommendations indicated on the manufacturer's documentation for the generating unit or the complete system.*

## STOPPING THE ENGINE

1. Before stopping the engine, allow it to run for a few minutes, with no load; this allows a uniform reduction in the water and oil temperature, avoiding serious damage to the engine caused by thermal shock.

2. The engine is stopped as described below:

switch off the power to the electronic governor and to the fuel shut-off solenoid valve fitted to the injection pump.

The control methods vary depending on the configuration of the control panel.

## **PRECAUTIONS FOR NORMAL ENGINE OPERATION**

The same precautions indicated in the corresponding section for industrial engines apply, apart from point "I" as specified below.

I. Apart from engines for emergency generating units, for which the operating restrictions indicated in the commercial documentation apply and for which electric pre-heating must be provided, it is recommended that the engine is heated with reduced loads before full load is applied.

## **CHECKS AND MAINTENANCE**

The same procedures apply as indicated in the corresponding industrial engine section, apart from the "Maintenance" operation specified below.

Replace crankshaft damper (1):

- engines 8065U06, 8065SU07.....9000 hours (2)
- engines 8061SRU26, 8065SRU26 .....5000 hours (2)

(1)The intervals for this operation may vary depending on engine use and the ambient conditions in which it operates.

(2)Whenever the engine undergoes a general overhaul.

## **ENGINE FAULT DIAGNOSIS**

The diagnosis of the faults described below refers to the general causes which are valid for the majority of the applications; faults caused by specific configurations of the machine or installation on which the engine is installed cannot be envisaged.

Engine faults can be remedied, depending on their type by:

- user
- qualified personnel
- authorised workshop.

The table overleaf describes only those operations that the user and the qualified personnel are authorised to perform to eliminate faults. All other circumstances should be referred to an authorised workshop equipped with the appropriate equipment and in possession of adequate technical information.

<b>Fault</b>	<b>Possible cause</b>	<b>Carried out by/remedy</b>
The engine does not start	Batteries not fully charged	Qualified personnel: check and recharge the batteries. Change if necessary.
	Battery terminal connections corroded or loose	Qualified personnel: clean, inspect and tighten the battery terminal nuts. Change the terminals and nuts if they are badly corroded.
	Insufficient fuel reserve	User: fill up
	Type of fuel not suited for temperatures below freezing.	Qualified personnel: change the fuel filter; then use a fuel suitable for winter use.
	Air in fuel system	Qualified personnel: check lines, connections, fuel pump, filters and injection pump for air; bleed as necessary.

<b>Fault</b>	<b>Possible cause</b>	<b>Carried out by/remedy</b>
The engine does not start	Other	Consult authorised workshop
	Fuel filters clogged	Qualified personnel: remove the filtering elements and change if necessary.
The engine stops	Air in the fuel system.	Qualified personnel: check lines, connections, fuel pump, filters and injection pump for air; bleed system.
	Other	Consult an authorised workshop.
The engine overheats	Radiator/cooler clogged	User: clean the radiator air intake surfaces (dust, mud, straw etc).

<b>Fault</b>	<b>Possible cause</b>	<b>Carried out by/remedy</b>
The engine overheats	Not enough tension on water pump and fan drive belt	Qualified personnel: check and adjust the belt tension
	Coolant level too low	User: top up the radiator to the right level with the correct fluid
	Air cleaner obstructed	Qualified personnel: clear the air cleaner and the whole system connected to it.
The engine is losing power and its operation is irregular	Impurities or water in the fuel and injection system	Qualified personnel: clean thoroughly and refill with fuel
	Fuel filters clogged	Qualified personnel: remove the filtering elements and change if necessary.
	Air cleaner obstructed	Qualified personnel: clean the air cleaner and the whole system connected to it.
There is abnormal knocking in the engine	Various	Refer to authorised workshop

<b>Fault</b>	<b>Possible cause</b>	<b>Carried out by/remedy</b>
The engine is smoking unduly: black or dark grey smoke	Air cleaner clogged or deteriorated	Qualified personnel: clean or replace the filtering element
	Defective injectors	Qualified personnel: check the injectors
Conspicuous and persistent blue, grey-blue smoke	Various	Refer to authorised workshop
The engine does not stop	Various	Refer to authorised workshop

## **MAINTENANCE PROCEDURES WHEN ENGINE IS OUT OF COMMISSION FOR LONG PERIODS**

If the engine has to remain out of commission for a period of more than 2 months, it should be protected from oxidation and faults in the following way:

1. Drain the oil from the sump and refill with flushing oil (e.g. FIAT L20 oil). This operation applies only for engines which have already operated for more than 200 hours.

2. Run the engine for 15 minutes at 500-800 rpm; stop the engine and drain the oil. This operation applies only for those engines which have already operated for more than 200 hours.

3. Drain all the oil contained in the in-line injection pump.

4. Pour into the engine sump FIAT Prot. 30/M oil up to the "Min" level indicated on the dipstick. If Prot. 30/M oil is not available use a brand oil which meets requirements MIL-2160B - type 2.

5. Pour Prot. 30/M oil into the in-line injection pump.

6. After loosening the fuel filters, disconnect the injection system line up-stream the fuel pump, and connect it to a special tank containing CFB oil (ISO 4113).

7. Run the engine for 15 minutes at 500- 800 rpm; at the end, using a syringe, slowly nebulise (in about 1 minute) the following quantity of Prot. 30/M oil in the intake manifold:

- 60 grammes in 3-4 cylinder engines
- 120 grammes in 6-cylinder engines

8. With the engine warm, drain the Prot. 30/M oil poured into the sump; the oil can be reused two or three more times. Slacken all the Vee-belts.

9. Detach the injection system fuel line from the tank containing the CFB oil and reconnect it to the fuel tank.

10. Seal with adhesive tape all the access, vent and bleed openings on the engine and exhaust pipe.

11. Affix a clearly visible label to the engine indicating that the unit is "WITHOUT ENGINE OIL".

12. Disconnect the batteries and place them in a dry place. Keep them charged all the time.

13. Drain the coolant if it does not include anti-freeze/corrosion inhibitor.

**IMPORTANT - THIS TREATMENT MUST BE REPEATED EVERY 6 MONTHS.**

## RESTORING OPERATING CONDITIONS

To restore normal operating conditions, carry out the following operations:

- 1) Drain the Prot. 30/M oil contained in the injection pump.
- 2) Pour oil into the engine sump and injection pump up to the specified level.
- 3) Adjust the tension of all the Vee-belts.
- 4) Remove the seals from the access, vent and bleed openings.
- 5) Remove the label with the indication "WITHOUT ENGINE OIL".



## MAIN REGULATION AND REPAIR DATA

Firing order (models 8035)	_____	1-2-3
Firing order (models 8045)	_____	1-3-4-2
Firing order (models 8065/8061)	_____	1-5-3-6-2-4
Valve clearance, engine cold:		
- intake and exhaust	_____	0.30 mm
Injector setting		260 + 10 bar
Max. water temperature	_____	98°C
Minimum oil pressure (industrial engines):		
- max speed	_____	3 kg/cm <sup>2</sup>
- min speed	_____	0.7 kg/cm <sup>2</sup>
Minimum oil pressure (generating unit engines):		
- calibration speed	_____	2 kg/cm <sup>2</sup>

### Tightening torques

Cylinder head:

- 1st phase (pre-torque)	.....	70 Nm (7.1 kgm)
- 2nd phase (pre-torque check)	.....	70 Nm (7.1 kgm)
- 3rd phase (angle)	.....	90°
- 4th phase (angle)	.....	90°
Connecting rod caps	.....	40 Nm (4.1 kgm) + 60°
Main bearing caps	.....	80 Nm (8.2 kgm) + 90°
Pulley-damper hub nut	.....	294 Nm (30 kgm)
Flywheel screws (*)	.....	40 Nm (4.1 kgm) + 60°

(\*) Lubricate with "Loctite HVX576".

## CAPACITIES

Parts	Quantity		Products
	l	kg	
Cooling system			
8035	~5	-	mixture of water and 50% Paraflu 11 (1)
8045	~6.7		
8065/8061	~11.5		
Engine sump and filter (total capacity)			
8035	7.7	7	Urania Turbo / Turbo LD (3)
8045U(8045SU)	11.5 (10.5)	10.5 (9.5)	
8065/8061	12.7	11.5	
Sump only: - min.level			
8035	4.4	4	
8045U(8045SU)	7.2 (6.4)	6.5 (5.8)	
8065/8061	6	5.5	
Sump only: - max. level(2)			
8035	6.6	6	
8045U(8045SU)	10.5 (9)	9.5 (8.2)	
8065/8061	10	9	
Fuel tank	-	-	Diesel (4)

1) Use a mixture of water and 50% Paraflu 11 in the summer months as well to provide optimal protection of the cooling system. As an alternative to PARAFLU 11, a similar product can be used provided that it corresponds to international specifications SAEJ 1034.

2) The quantity indicated is that required for routine oil changes.

3) Use lubricants corresponding to the following international specifications: ACEA E3-96 (e.g. URANIA TURBO LD) for turbocharged engines ; ACEA E2-96/API CF4/MIL L 2104E (e.g. URANIA TURBO) for naturally aspirated engines.

The foregoing is valid for an engine change every 300 hours.

As regards the quality of oil to be used in relation to ambient temperature, see the table on the following page.

4) With atmospheric temperature below freezing, use a winter-type fuel.



### WARNING

*If fuel with a sulphur content of more than 0.5% or oil type ACEA E2-96/API CF4/MIL L 2104E (e.g. URANIA TURBO) is used in turbocharged engines, the engine oil change must be reduced to every 200 hours.*

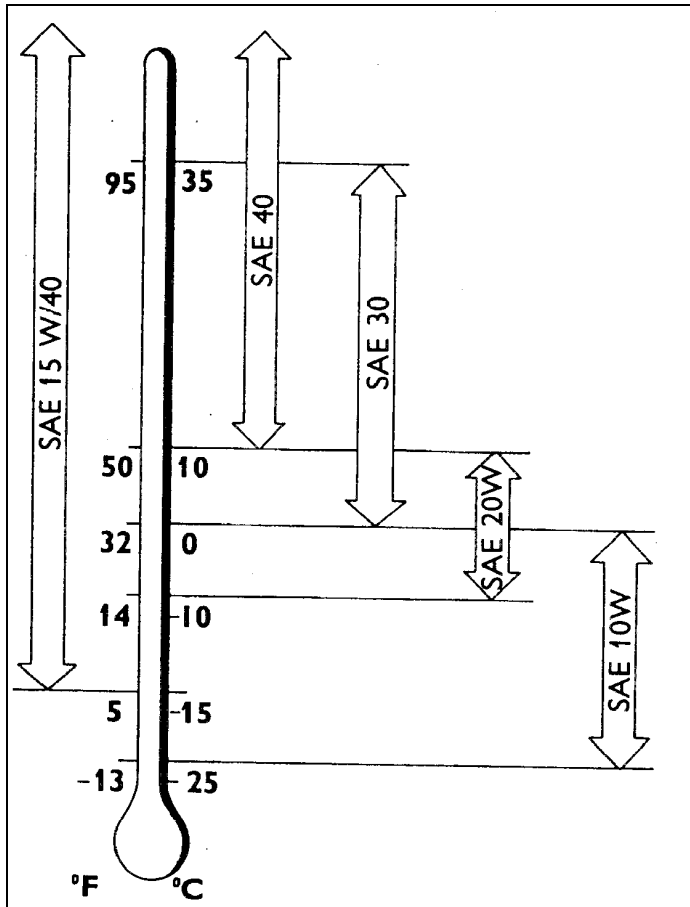

### USE OF THE ENGINE OIL

For the engine to operate properly and in order to comply with the specifications indicated in the paragraph "Capacities", the SAE viscosity of the oil used must correspond to the values indicated in relation to the outdoor temperature.



## HANDLING THE ENGINE

If the engine is dismantled and then reassembled on the machine, the appropriate operations must be carried out solely by authorised workshops which are equipped with the appropriate lifting and handling equipment.

The eyes to be used to lift only the engine are indicated in this manual in the section "Engine views" and, on the engine, by special labels.

All the lifting eyes available must be used at the same time; **the use of just one eye is forbidden.**

It is not permitted to lift the engine before removing the transmission components connected to it or other machine components supported by the engine.

The capacity and size of the engine lifting system must be adequate for the weight and size of the engine; in particular, check that there is no fouling between the lift system and the engine components.

It is important to use a lift balance to hold the metal lift cables parallel.

## DISPOSAL

Please note that the engine and its components contain material necessary for its operation which, if dispersed in the environment, may cause ecological damage.

The following materials must be consigned to special authorised collection centres:

- starter batteries
- used lubricating oils
- mixtures of water and anti-freeze
- filters
- auxiliary cleaning material (e.g. dirty or fuel-sodden rags)

Severe penalties are envisaged for transgressors, in accordance with the laws in force in every country.

## WHAT TO DO IN AN EMERGENCY

Any user of the machine, constructed according to safety regulations, who follows the instructions set out in this manual and complies with the instructions on the labels affixed to the engine is working in safe conditions.

If operating mistakes cause accidents call for help immediately from the emergency services.

In the event of an emergency, and whilst awaiting the arrival of the emergency services, the following general advice is given for the provision of first aid.

### Fire

Put out the fire using extinguishers recommended by the manufacturer of the machine or the installation..

### Burns

1) Put out the flames on the clothing of the burns victim by means of:

- drenching with water
- use of powder extinguisher, making sure not to direct the jets onto the face
- blankets or rolling the victim on the ground.

2) Do not pull off strips of clothing which are sticking to the skin

3) In the case of scalding with liquids, remove the soaked clothing quickly but carefully;

4) cover the burn with a special anti-burn packet or with a sterile bandage.

### Carbon monoxide poisoning (CO)

Carbon monoxide contained in engine exhaust gases is odourless and dangerous because it is poisonous and because, with the air, it forms an explosive mixture.

Carbon monoxide is very dangerous in enclosed premises because it can reach a critical concentration in a short time.

When attending a person suffering from CO poisoning in enclosed premises, ventilate the premises immediately to reduce the gas concentration.

When accessing the premises, the person providing the aid must hold his breath, not light flames, turn on lights or activate electric bells or telephones so as to avoid explosions.

Take the victim to a ventilated area or into the open air, placing him on his side if he is unconscious.

### Caustic burns

1) Caustic burns to the skin are caused by acid escaping from the batteries:

- remove the clothes
- wash with running water, being careful not to affect injury-free areas

2) Caustic burns to the eyes are caused by battery acid, lubricating oil and diesel fuel.

- wash the eye with water for at least 20 minutes, keeping the eyelids open so that the water runs over the eyeball and moving the eye in all directions.

## **Electrocution**

Electrocution can be caused by:

- 1) the engine's electrical system (12/24 V)
- 2) the electrical generator system (generating units)

In the first case, the low voltage does not involve high current flows through the human body; however, if there is a short circuit, caused by a metal tool, sparks and burns may occur.

In the second case, the high voltage causes strong currents which can be extremely dangerous.

If this happens, break the current by operating the switch before touching the injured person.

If this is not possible, bear in mind that any other attempt is highly dangerous also for the person assisting; therefore, any attempt to help the victim must be carried out without fail using means which are insulating.

## **Wounds and fractures**

The wide range of possible injuries and the specific nature of the help needed means that the medical services must be called.

If the person is bleeding, compress the wound externally until help arrives.

In the case of fracture do not move the part of the body affected by the fracture. Move the injured person with extreme care and then only if strictly necessary.