

**USE AND MAINTENANCE
USO E MANUTENZIONE
UTILISATION ET ENTRETIEN
BETRIEB UND WARTUNG
USO Y MANTENIMIENTO**

INDUSTRIAL ENGINES

NEF SERIES

MECHANICAL INJECTION SYSTEM

Publication edited by
Marketing - Adv. & Promotion
Print L31900009 - 10/05

**IVECO
MOTORS**



NEF SERIES

MECHANICAL INJECTION SYSTEM

N45 MNA - N45 MSA (TIER 2)

N45 MNS - N45 MSS (TIER 2/3)

N45 MNT - N45 MST (TIER 2/3)

N67 MNT - N67 MST (TIER 2/3)

NEF 45 TM1

NEF 45 TM2

NEF 67 SM1

NEF 67 TM2

NEF 67 TM3

USE AND MAINTENANCE

INTRODUCTION

We would like to thank you for buying an IVECO MOTORS product, and compliment you on your choice of engine.

Before you carry out any operation involving the engine or its fittings, please read the contents of this manual carefully; compliance with the instructions provided in the manual is the best way to guarantee trouble-free, long term operation of the engine.

The contents of this manual refer to the standard configuration of the engine, and the illustrations are purely indicative. Some instructions are provided by giving the sequence of operations to be carried out in order to allow the engine and/or its fittings to perform in a certain way. In some cases they will be dependent on the configuration of the commands and the set-up of the machine on which the engine is installed; for any points that differ from the contents of this manual, please consult the instructions provided by the machine Manufacturer or a specific manual.

The information provided below was current at the date of publication.

The Manufacturer reserves the right to make modifications at any time without prior notice, for technical or commercial reasons or to update the engines to comply with legal requirements in the various Countries.

The Manufacturer declines all liability for any errors or omissions.

Please remember that the IVECO MOTORS Technical Service Network is available to offer you its experience and professional skills, wherever you may be.

TABLE OF CONTENTS

	Page		Page
■ GENERAL INFORMATION	3	■ LONG PERIODS OF INACTIVITY	37
Guarantee	3	Preparing the engine for a long period of inactivity	37
Spare Parts	3	Restarting the engine after a long period of inactivity	38
Liability	3	■ BEHAVIOUR IN AN EMERGENCY	39
Safety	3	■ IN APPENDIX	
Engine technical data N45 MNA - N45 MSA	4	Oil viscosity level according to surrounding temperatures	
Engine technical data N45 MNS / MSS / MNT / MST	6		
Engine technical data N67 MNT - N67 MST	8		
Engine technical data NEF 45 TM1 / TM2	10		
Engine technical data NEF 67 SM1	12		
Engine technical data NEF 67 TM2 / TM3	14		
Signs	16		
■ USE	17		
Preliminary checks	17		
Starting and stopping the engine	17		
Recognising alarms	20		
Engine pre-heating	21		
For proper use of the engine	21		
Special warnings	22		
Running in	23		
Refuelling	24		
■ CONTROLS AND MAINTENANCE	25		
Maintenance personnel	25		
Accident prevention	25		
Frequency	26		
Requirements	27		
How to proceed	28		
Moving the engine	36		
Disposal of waste	36		

■ GENERAL INFORMATION

GUARANTEE

In order to ensure that your engine gives the best possible performance and to take advantage of the IVECO MOTORS guarantee, you must follow the indications provided in this publication with great care; failure to do so may result in invalidation of the guarantee.

SPARE PARTS

Always use Original IVECO MOTORS Spare parts. This is essential to keep the engine in original running order.

The use of non-original spare parts will not only invalidate the guarantee, but will mean that IVECO MOTORS will not be considered liable in any way during the whole working life of the engine.

LIABILITY

The Manufacturer will only be considered liable subject to performance of the control and maintenance operations indicated and described in this manual; to this effect, proof that these operations have been performed must be provided. Any special maintenance operations that may be necessary must be carried out by qualified technicians from authorised Workshops in the IVECO MOTORS Network, using the instruments and equipment provided for the purpose.

SAFETY

The following information is intended to encourage caution when using the engine, so as to avoid damage to persons or property as a result of improper or incorrect behaviour.

- ❑ The engines must only be used for the purposes indicated by the Manufacturer.
- ❑ Any tampering, modification and use of non-original spare parts may compromise proper operation and safe use of the engine; **never, under any circumstances** make modifications to the wiring and to the units equipping the engine, or connect them to other power systems.
- ❑ Pay particular attention to moving parts of the engine, to high temperature components and to circuits containing pressurised fluids; its electrical equipment houses electrical currents and voltage.
- ❑ The exhaust fumes produced by the engine are bad for your health.
- ❑ tackle, making use of the U-bolts provided on the engine for that purpose.
- ❑ The engine must not be started up and used until the machine in which it installed has satisfied all necessary safety requirements, or until the machine has been guaranteed to comply with local laws and regulations.
- ❑ The operations required to guarantee the best possible use and preservation of the engine must only be carried out by persons of proven experience, equipment with tools considered suitable by IVECO MOTORS.

For the purpose of safety, further recommendations are given in the chapter CONTROLS AND MAINTENANCE.

ENGINE TECHNICAL DATA N45 MNA - N45 MSA

The technical code and serial number are indicated on a plate, which is located on different parts of the engine, according to the model: flywheel casing, tappet cover, other.

Code	N45 MNA / MSA
Engine family	F4
Cycle	4-stroke diesel
Number and arrangement of cylinders	4, in line
Bore x stroke	104 x 132 mm
Total displacement	4,500 cm ³
Air system	Aspiration
Injection type	Direct with rotating pump
Engine direction of rotation	Anticlockwise (seen from flywheel side)
Dry weight	380 kg

Electrical system	12 V
Accumulator/s	
- capacity	180 Ah or above
- discharge current	950 A or above

Performance: Maximum power (*) Maximum torque

N45 MNA / MSA 60 kW (81 CV) @ 2300 rpm
320 Nm (33 Kgm) @ 1400 rpm

(*)Net power to the flywheel in compliance with ISO 3046-1. Test conditions: temperature 25 °C; atmospheric pressure 100 kPa; relative humidity 30%.

WARNING

Any alteration of the above mentioned characteristics, in particular modification of the data stored in the injection system electronic units or the characteristics of the engine and its fittings, is strictly prohibited, penalty invalidation of the guarantee and absence of all liability on the part of IVECO MOTORS.

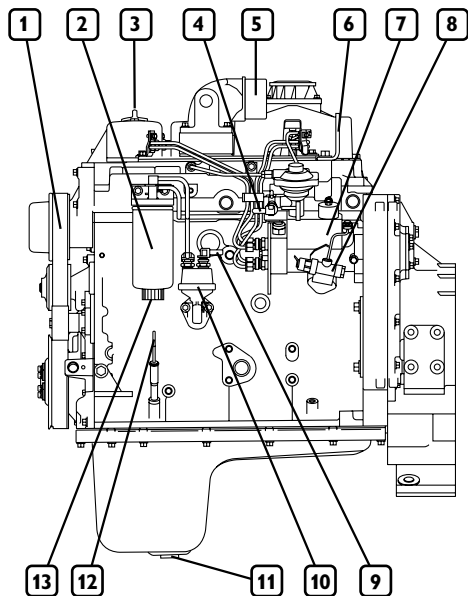

05_591_N

Engine N45 MNA - N45 MSA

1. Auxiliary member drive belt - 2. Fuel filter - 3. Oil filler cap - 4. Fuel outlet connector to tank - 5. Engine air inlet - 6. Lifting U-bolt - 7. Injection pump - 8. Cold injection timing variator - 9. Fuel inlet manifold from tank - 10. Fuel supply pump - 11. Oil drainage plug - 12. Oil dipstick - 13. Fuel filter condensation drainage plug.

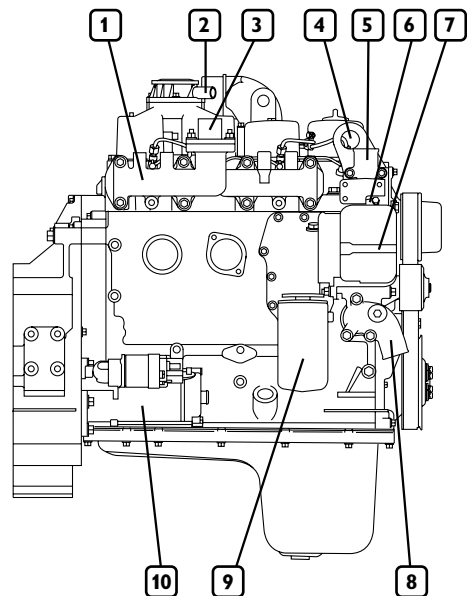

05_592_N

Engine N45 MNA - N45 MSA

1. Exhaust manifold - 2. Oil vapour bleeder - 3. Exhaust outlet - 4. Lifting U-bolt - 5. Engine coolant outlet - 6. Location of thermostat valve - 7. Alternator - 8. Engine coolant inlet - 9. Lubricant oil filter - 10. Electrical starter motor.

ENGINE TECHNICAL DATA N45 MNS/MSS/MNT/MST

The technical code and serial number are indicated on a plate, which is located on different parts of the engine, according to the model: flywheel casing, tappet cover, other.

Code	N45 MNS / MSS / MNT / MST
Engine family	F4
Cycle	4-stroke diesel
Number and arrangement of cylinders	4, in line
Bore x stroke	104 x 132 mm
Total displacement	4,500 cm ³
Air system	Supercharged - Aftercooled ⁽¹⁾
Injection type	Direct with rotating pump
Engine direction of rotation	Anticlockwise (seen from flywheel side)
Dry weight	390 kg

(1) Only for N45 MNT / MST engines

Electrical system	12 V
Accumulator/s	
- capacity	180 Ah or above
- discharge current	950 A or above

Performance:	Maximum power (*) Maximum torque
N45 MNS / MSS	74 kW (100 CV) @ 2300 rpm 398 Nm (40.5 Kgm) @ 1400 rpm
N45 MNT / MST	94 kW (128 CV) @ 2300 rpm 500 Nm (50.9 Kgm) @ 1400 rpm

(*)Net power to the flywheel in compliance with ISO 3046-1. Test conditions: temperature 25 °C; atmospheric pressure 100 kPa; relative humidity 30%.

WARNING
<i>Any alteration of the above mentioned characteristics, in particular modification of the data stored in the injection system electronic units or the characteristics of the engine and its fittings, is strictly prohibited, penalty invalidation of the guarantee and absence of all liability on the part of IVECO MOTORS.</i>

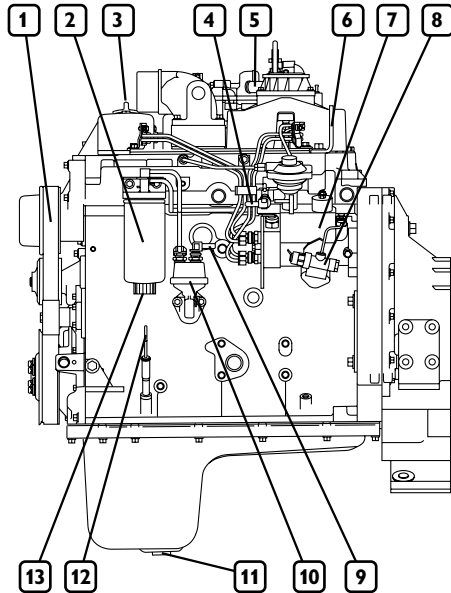

05_595_N

Engine N45 MNS/MSS/MNT/MST

1. Auxiliary member drive belt - 2. Fuel filter - 3. Oil filler cap - 4. Fuel outlet connector to tank - 5. Oil vapour bleeder - 6. Lifting U-bolt - 7. Injection pump - 8. Cold injection timing variator - 9. Fuel inlet manifold from tank - 10. Fuel pump - 11. Oil drainage plug - 12. Oil dipstick - 13. Fuel filter condensation drainage plug.

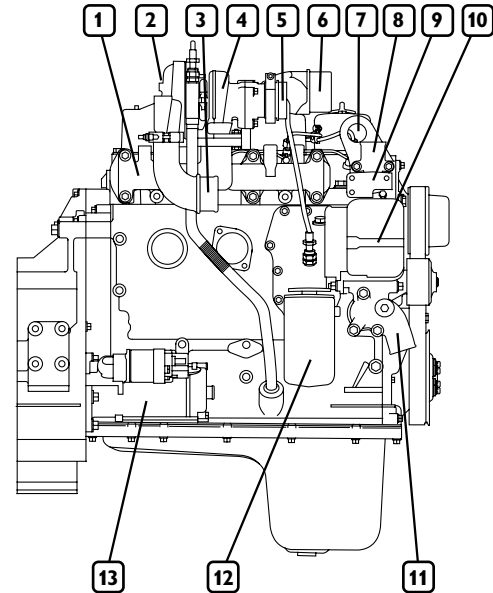

05_596_N

Engine N45 MNS/MSS/MNT/MST

1. Exhaust manifold - 2. Turbocharger air inlet - 3. Turbocharging air outlet (only for N45 MNT / MST engines) - 4. Turbocharger - 5. Turbocharger exhaust outlet - 6. Engine air inlet - 7. Lifting U-bolt - 8. Engine coolant outlet - 9. Location of thermostat valve - 10. Alternator - 11. Engine coolant inlet - 12. Oil filter - 13. Electric starter motor.

ENGINE TECHNICAL DATA N67 MNT - N67 MST

The technical code and serial number are indicated on a plate, which is located on different parts of the engine, according to the model: flywheel casing, tappet cover, other.

Code	N67 MNT - N67 MST
Engine family	F4
Cycle	4-stroke diesel
Number and arrangement of cylinders	6, in line
Bore x stroke	104 x 132 mm
Total displacement	6,700 cm ³
Air system	Supercharged and aftercooled
Injection type	Direct with rotating pump
Engine direction of rotation	Anticlockwise (seen from flywheel side)
Dry weight	530 kg
Electrical system 12 V	
Accumulator/s	
- capacity	180 Ah or above
- discharge current	950 A or above

Performance: Maximum power (*) Maximum torque

N67 MNT / MST 120 kW (163 CV) @ 2300 rpm
630 Nm (64 Kgm) @ 1400 rpm

(*)Net power to the flywheel in compliance with ISO 3046-1. Test conditions: temperature 25 °C; atmospheric pressure 100 kPa; relative humidity 30%.

WARNING

Any alteration of the above mentioned characteristics, in particular modification of the data stored in the injection system electronic units or the characteristics of the engine and its fittings, is strictly prohibited, penalty invalidation of the guarantee and absence of all liability on the part of IVECO MOTORS.

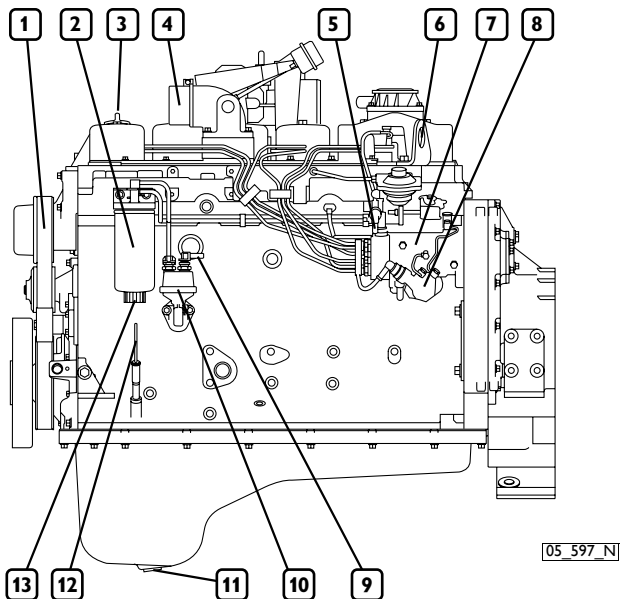

Engine N67 MNT - N67 MST

1. Auxiliary member drive belt - 2. Fuel filter - 3. Oil filler cap - 4. Engine intake - 5. Fuel outlet connector to tank - 6. Lifting U-bolt - 7. Injection pump - 8. Cold injection timing variator - 9. Fuel inlet manifold from tank - 10. Fuel pump - 11. Oil drainage plug - 12. Oil dipstick - 13. Fuel filter condensation drainage plug.

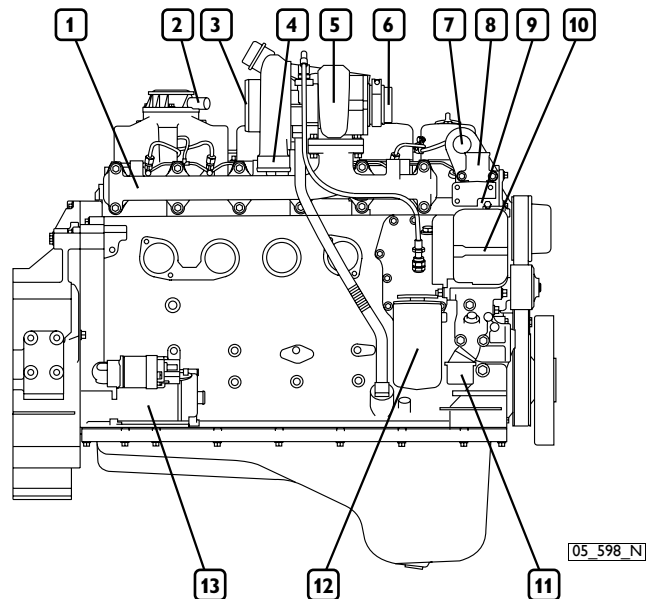

Engine N67 MNT - N67 MST

1. Exhaust manifold - 2. Oil vapour bleeder - 3. Turbocharger air inlet - 4. Turbocharging air outlet - 5. Turbocharger - 6. Turbocharger exhaust outlet - 7. Lifting U-bolt - 8. Engine coolant outlet - 9. Location of thermostat valve - 10. Alternator - 11. Engine coolant inlet - 12. Lubricant oil filter - 13. Electrical starter motor.

ENGINE TECHNICAL DATA NEF 45 TM1 / TM2

The technical code and serial number are indicated on a plate, which is located on different parts of the engine, according to the model: flywheel casing, tappet cover, other.

Code		NEF 45 TM1 / TM2	
Engine family	F4		
Cycle	4-stroke diesel		
Number and arrangement of cylinders	6, in line		
Bore x stroke	104 x 132 mm		
Total displacement	6,700 cm ³		
Air system	Supercharged and aftercooled		
Injection type	Direct with rotating pump		
Engine direction of rotation	Anticlockwise (seen from flywheel side)		
Speed regulator	Mechanical		
Dry weight	530 kg		
Electrical system		12 V	
Accumulator/s			
- capacity	180 Ah or above		
- discharge current	950 A or above		

Performance (*)		NEF 45 TM1	
(50 Hz)	Prime kWm @ 1500 rpm	
	Stand by	84 kWm @ 1500 rpm	
(60 Hz)	Prime kWm @ 1800 rpm	
	Stand by	95 kWm @ 1800 rpm	

Performance (*)		NEF 45 TM2	
(50 Hz)	Prime kWm @ 1500 rpm	
	Stand by	95 kWm @ 1500 rpm	
(60 Hz)	Prime kWm @ 1800 rpm	
	Stand by	107 kWm @ 1800 rpm	

(*)Values in compliance with ISO 8528.

WARNING	
<p><i>Any alteration of the above mentioned characteristics, in particular modification of the data stored in the injection system electronic units or the characteristics of the engine and its fittings, is strictly prohibited, penalty invalidation of the guarantee and absence of all liability on the part of IVECO MOTORS.</i></p>	

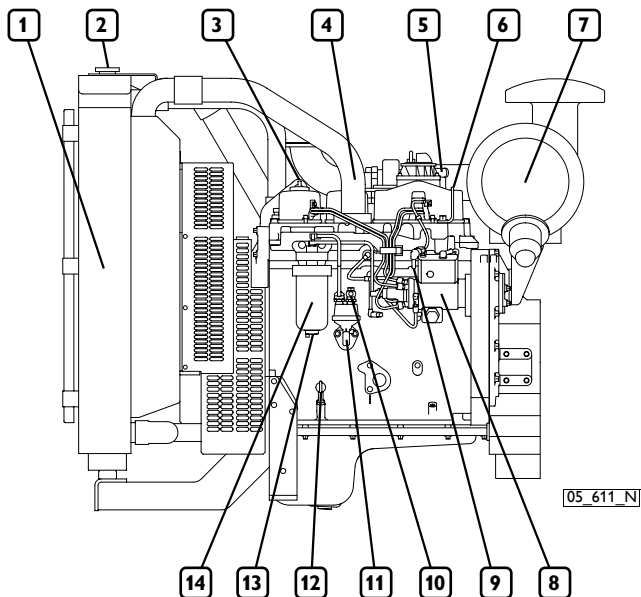

Engine NEF 45 TM1 / TM2

1. Heat exchanger/s - 2. Coolant filler cap - 3. Oil filler cap - 4. Engine air inlet manifold - 5. Oil vapour bleeder - 6. Lifting U-bolt - 7. Air filter - 8. Injection pump - 9. Fuel outlet connector to tank - 10. Fuel inlet manifold from tank - 11. Hand pump - 12. Oil dipstick - 13. Fuel filter condensation drainage plug - 14. Fuel filter.

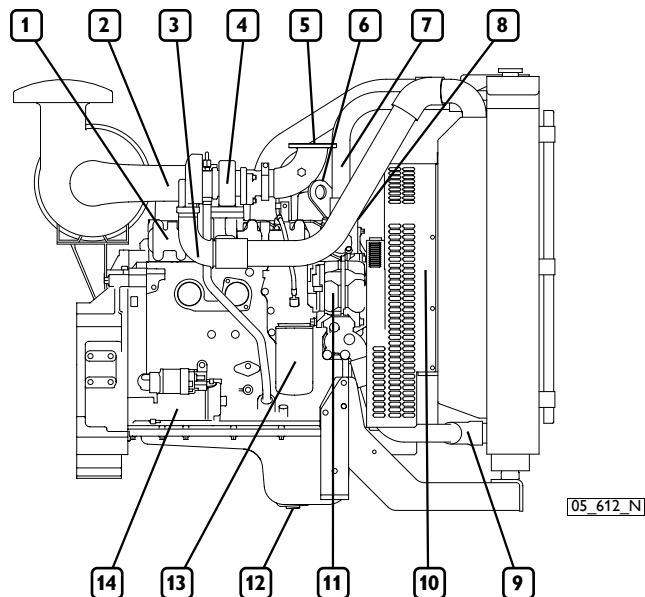

Engine NEF 45 TM1 / TM2

1. Exhaust manifold - 2. Turbocharger air intake - 3. Turbocharging air outlet - 4. Turbocharger - 5. Exhaust outlet - 6. Lifting U-bolt - 7. Coolant outlet manifold from engine - 8. Location of thermostat valve - 9. Engine coolant inlet connector sleeve - 10. Fan - 11. Alternator - 12. Lubricant oil discharge plug - 13. Oil filter - 14. Electrical starter motor.

ENGINE TECHNICAL DATA NEF 67 SM1

The technical code and serial number are indicated on a plate, which is located on different parts of the engine, according to the model: flywheel casing, tappet cover, other.

Code	NEF 67 SM1
Engine family	F4
Cycle	4-stroke diesel
Number and arrangement of cylinders	6, in line
Bore x stroke	104 x 132 mm
Total displacement	6,700 cm ³
Air system	Supercharged
Injection type	Direct with rotating pump
Engine direction of rotation	Anticlockwise (seen from flywheel side)
Speed regulator	Mechanical
Dry weight	530 kg

Electrical system	12 V
Accumulator/s	
- capacity	180 Ah or above
- discharge current	950 A or above

Performance (*)	NEF 67 SM1	
(50 Hz)	Prime	110 kWm @ 1500 rpm
	Stand by	121 kWm @ 1500 rpm
(60 Hz)	Prime	126 kWm @ 1800 rpm
	Stand by	138 kWm @ 1800 rpm

(*) Values in compliance with ISO 8528.

WARNING
<i>Any alteration of the above mentioned characteristics, in particular modification of the data stored in the injection system electronic units or the characteristics of the engine and its fittings, is strictly prohibited, penalty invalidation of the guarantee and absence of all liability on the part of IVECO MOTORS.</i>

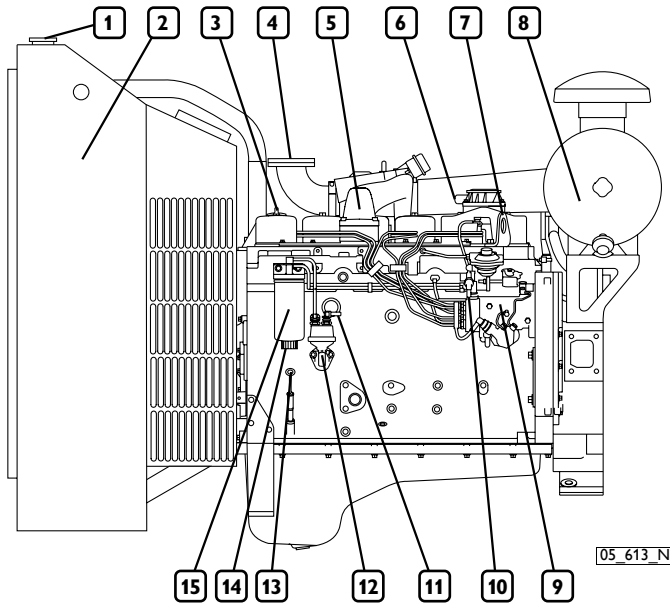

Engine NEF 67 SM1

1. Coolant filler cap - 2. Heat exchanger/s - 3. Oil filler cap - 4. Exhaust gas discharge - 5. Engine air inlet manifold - 6. Oil vapour bleeder - 7. Lifting U-bolt - 8. Air filter - 9. Injection pump - 10. Fuel outlet manifold to tank - 11. Fuel inlet manifold from tank - 12. Hand pump - 13. Oil dipstick - 14. Fuel filter condensation drainage plu - 15. Fuel filter.

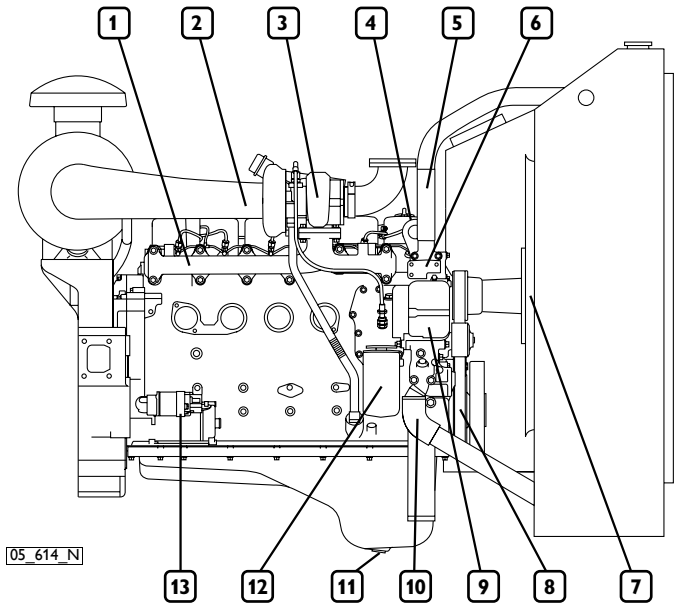

Engine NEF 67 SM1

1. Exhaust manifold - 2. Turbocharger air intake - 3. Turbocharger - 4. Lifting U-bolt - 5. Coolant outlet manifold from engine - 6. Thermostat valve location - 7. Fan - 8. Auxiliary member drive belt - 9. Alternator - 10. Engine coolant inlet sleeve - 11. Lubricant oil discharge plug - 12. Oil filter - 13. Electrical starter motor.

ENGINE TECHNICAL DATA NEF 67 TM2 / TM3

The technical code and serial number are indicated on a plate, which is located on different parts of the engine, according to the model: flywheel casing, tappet cover, other.

Code		NEF 67 TM2 - NEF 67 TM3	
Engine family	F4		
Cycle	4-stroke diesel		
Number and arrangement of cylinders	6, in line		
Bore x stroke	104 x 132 mm		
Total displacement	6,700 cm ³		
Air system	Supercharged and aftercooled		
Injection type	Direct with rotating pump		
Engine direction of rotation	Anticlockwise (seen from flywheel side)		
Speed regulator	Mechanical		
Dry weight	530 kg		
Electrical system		12 V	
Accumulator/s			
- capacity	180 Ah or above		
- discharge current	950 A or above		

Performance (*)		NEF 67 TM2	
(50 Hz)	Prime	114 kWm @ 1500 rpm	
	Stand by	125 kWm @ 1500 rpm	
(60 Hz)	Prime	127 kWm @ 1800 rpm	
	Stand by	140 kWm @ 1800 rpm	

Performance (*)		NEF 67 TM3	
(50 Hz)	Prime	138 kWm @ 1500 rpm	
	Stand by	152 kWm @ 1500 rpm	
(60 Hz)	Prime	150 kWm @ 1800 rpm	
	Stand by	165 kWm @ 1800 rpm	

(*)Values in compliance with ISO 8528.

WARNING	
<p><i>Any alteration of the above mentioned characteristics, in particular modification of the data stored in the injection system electronic units or the characteristics of the engine and its fittings, is strictly prohibited, penalty invalidation of the guarantee and absence of all liability on the part of IVECO MOTORS.</i></p>	

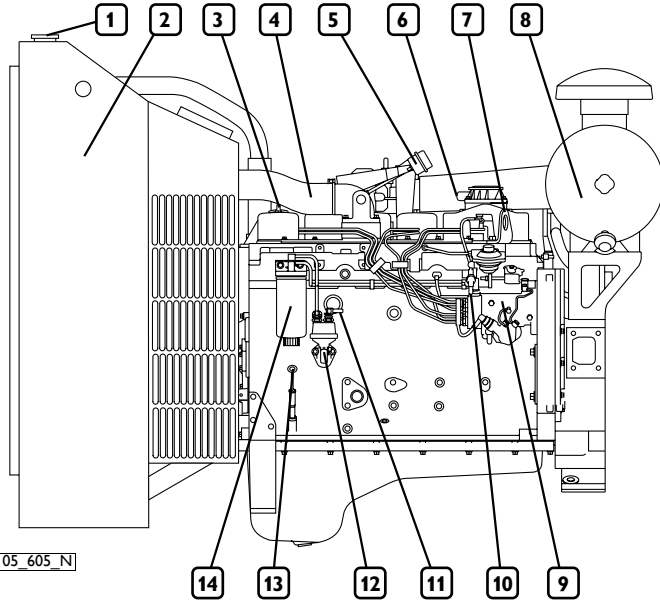

Engine NEF 67 TM2 / TM3

1. Coolant filler cap - 2. Heat exchanger/s - 3. Oil filler cap - 4. Engine air inlet manifold - 5. Waste-gate - 6. Oil vapour bleeder - 7. Lifting U-bolt - 8. Air filter - 9. Injection pump - 10. Fuel outlet connector to tank - 11. Fuel inlet manifold from tank - 12. Hand pump - 13. Oil dipstick - 14. Fuel filter.

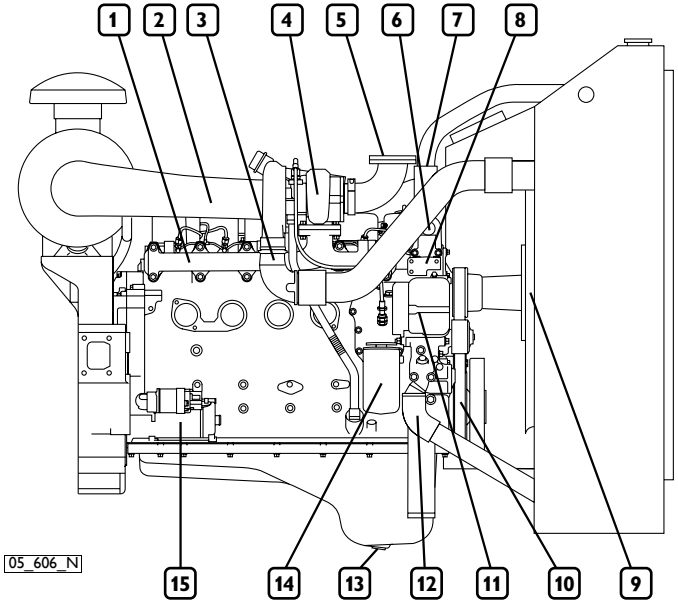

Engine NEF 67 TM2 / TM3

1. Exhaust manifold - 2. Turbocharger air intake - 3. Turbocharging air outlet - 4. Turbocharger - 5. Exhaust gas discharge - 6. Lifting U-bolt - 7. Coolant outlet manifold from engine - 8. Thermostat valve location - 9. Fan - 10. Auxiliary member drive belt - 11. Alternator - 12. Engine coolant inlet sleeve - 13. Lubricant oil discharge plug - 14. Oil filter - 15. Electrical starter motor.

SIGNS

Certain warning signs are affixed to the engine by the Manufacturer, and their meanings are indicated below

N.B. The signs with an exclamation mark on them underline a potential **danger**.



Lifting point (engine only).



Fuel Cap
(on the fuel tank, if there is one).



Oil Cap.



Oil dipstick.



Danger of burning:
Expulsion of hot water under pressure.



Danger of burning:
Presence of high temperature parts.



Danger of fire:
Fuel present.

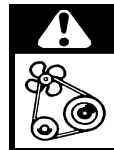

Danger of impact or catching
on moving parts:
Presence of fans, pulleys, belts or the like.

■ USE

PRELIMINARY CHECKS

Before starting the engine each time:

- ❑ Check the level of technical fluids (fuel, engine oil and coolant), and top-up if necessary.
- ❑ Make sure that the air aspiration filter is not blocked or obstructed, checking at the same time that the mechanical indicator on the filter does not show the “red” sign. If the engine is equipped with an electrical blockage sensor, an alarm will be displayed on start-up, by means of the indicator light on the instrument panel.

Note: The procedures required to clean the filter are indicated in the chapter CONTROLS AND MAINTENANCE.

CAUTION!



Make sure that no combustible vapours or gasses are present in the area in which the engine is to operate. Ensure that closed areas are adequately ventilated and fitted with a suitable exhaust extraction system.

STARTING AND STOPPING THE ENGINE

The start-up and shut-down operations described below apply to an on-board control panel manufactured by IVECO MOTORS; if the Manufacturer of the vehicle or machine has fitted a customised instrument panel, these operations may vary according to the various choices made during construction.

In these cases, follow the start-up/shut-down sequences and use the instrument panel description provided in the specific documentation.

Start-up from the IVECO MOTORS control panel (supplied on demand)

1. Insert the key into the switch (1) and turn it to the right to position **1B**. "Run". Once the indicator lights have been tested and the beeper has stopped sounding, make sure that the analogue instruments are showing values that conform with the relevant physical parameters of temperature, battery voltage and oil pressure; (information on how to interpret the indicators and alarms is given in the relevant paragraph)
2. If the engine is fitted with a pre-heating system (optional) and the engine temperature is lower than the minimum value foreseen for it to come into operation, wait for the relevant indicator light to go out.
3. Turn the key to position **1C** "Start" and release it once the engine has started, without accelerating.
4. Make sure that the "Alternator recharge" and "Oil pressure low" indicators have turned off and that the analogue instruments are showing values that conform with the relevant new physical parameters. If the pre-heating system has intervened, the relevant indicator will turn on again to indicate that the post-heating phase is in progress; the duration of this function is proportional to the temperature value.
5. If the engine does not start, after releasing the key it will only be possible to turn it back to the start position after first returning the switch to the rest position **1A**.

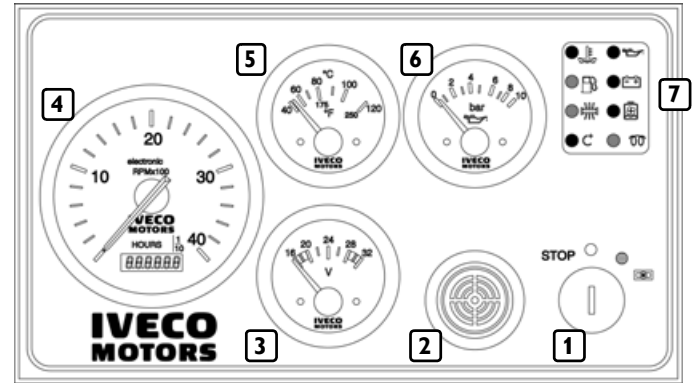

05_607_N

1. Key switch to start/stop the engine - 2. Beeper - 3. Voltmeter - 4. Rev counter and hour counter - 5. Coolant temperature indicator - 6. Engine oil pressure indicator - 7. Alarm and indicator module



05_580_N

1A "REST" position allowing the key to be removed

1B Stable "RUN" position

1C Unstable "START" position

STOP Unstable position used in EXCITED STOP set-ups for engines fuelled by a mechanical injection pump.

Start-up of a power generator

The start-up method described above may vary, depending on the solutions used to create the electric panels and the system control and running boards; so you should always comply with the indications provided by the Fitter of the power generating plants or the Manufacturer of the machine, even if the panels and control stations have been created using the same components used for IVECO MOTORS panels.

In any case, after start-up the engine will automatically revert to the selected running speed.

It is suggested that the engine be warmed up with a reduced load before applying the full load (*).

(*) With the exception of the emergency power generators, for which the operating limits indicated in the commercial documentation apply and for which the use of a pre-heating device is required (see following pages).

CAUTION!



The emergency power generator may start up at any time. During maintenance operations it is therefore essential that all the safety precautions set down by the Manufacturer of the generator or the Preparer of the system in which it is fitted be closely followed.

Stopping the engine from the IVECO MOTORS control panel

Before stopping the engine it is recommended you run it for a few minutes at minimum speed with no load; this will allow the temperature to drop evenly and will avoid harmful thermal shocks.

The shutdown method will depend on the type of equipment installed.

With “unexcited” stop circuit

- Turn the key switch to position **1A** - REST.

With “excited” stop circuit

- Turn the key switch to the **STOP** position.

In the absence of IVECO MOTORS control panels, always follow the instructions provided by the Manufacturer of the machine.

Should you intend to re-start the engine:

1. Return the key switch to the rest position **1A**, thus resetting all the on-board panel functions (only essential for electronically controlled engines).
2. Turn the key to position **1C** “Start” and release it once the engine has started, without accelerating.
3. Proceed as described previously.

RECOGNISING ALARMS

Indicator and alarm synoptics

The IVECO MOTORS instrument panel contains the indicator lights used to indicate the state of operation of the engine. Light-up of these indicators is piloted by electronic circuits, which have a simultaneous alarm timer and storage function.

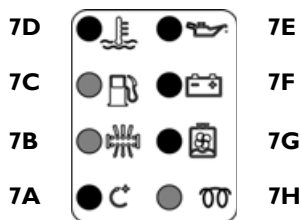

05_581_N

7A. Maximum allowed rotation speed exceeded (on request) - 7B. Air filter blocked - 7C. Fuel level low - 7D. Coolant temperature high - 7E. Oil pressure low - 7F. Alternator malfunction - 7G. Engine coolant level low - 7H. Pre-post heating.

Some types of engine and relevant equipment only make some of the functions indicated in the key available. If the machine Manufacturer uses different technical options there may also be further changes to the above.

Operation

When the key is turned in the switch to position **1B** an efficiency test is performed, for 5 seconds, on all the indicator lights, with the exception of the "Pre-post heating" indicator, while at the same time the beeper sounds.

During start-up and for the following 15 seconds, all synoptic functions are disabled; after this period, each critical state detected by the sensors provided on the engine will result in the relevant indicator lighting up.

Some alarms, which are of critical importance for efficient running of the engine, will not only light the relevant optical indicator, but will also start the beeper and cause automatic shutdown of the engine:

- Maximum allowed rotation speed exceeded
- Coolant temperature high
- Oil pressure low
- Engine coolant level low.

CAUTION!



In the event of momentary stoppages of the engine, pay attention to the synoptics and check for any alarm signals. Do not restart the engine until the cause of the problem has been removed or proper operating conditions have been restored.

ENGINE PRE-HEATING (optional)

(220 V, single phase electrical device)

The engines for which low temperature start-up and immediate delivery of power are required may be fitted with a 220 V single phase electrical heating device, which allows the temperature of the coolant to be raised to or maintained at suitable values. The device is fitted with a thermostat to cut the power supply when the required temperature is reached.

FOR PROPER USE OF THE ENGINE

(with the exception of power generator engines)

- ❑ Do not leave the key turned to the start position **1C**, when the engine has started.
- ❑ It is not efficient to leave the engine running at minimum speed while waiting for it to reach the proper working temperature; it is preferable that, after approximately one minute from start-up, you gradually increase the engine load.
- ❑ Do not leave the engine running at minimum speed for long, as this increases the production of harmful emissions and does not guarantee the best performance.
- ❑ The engine speed must be increased and decreased gradually, to allow regular combustion and proper operation of all engine components.
- ❑ The running speed and power values must comply with the specifications on the technical and commercial documentation.

During use, periodically check that:

1. The engine coolant temperature does not reach the alarm threshold.
2. The oil pressure remains within normal values.

If the temperature is considered too high, reduce speed and stop to check the state of the cooling system circuits; also check and have checked:

- a) the tension of the auxiliary member drive belt;
- b) operation of the thermostat valve;
- c) whether or not the heat exchanger is clean.

SPECIAL WARNINGS

Coolant circuit

When a state of “Coolant temperature high” and “Engine coolant level low” is found, this triggers stoppage of the engine; in these cases, check the efficiency of the circuit components, remembering that when the engine is warm, a pressure liable to cause hot liquid to be expelled with extreme violence is created within the cooling circuits. This results in a danger of burning.

CAUTION!



Only open the coolant tank cap if strictly necessary, and only when the engine is cold.

Lubrication circuit

When a state of “Oil pressure low”, is found, this triggers stoppage of the engine; in this case, check the oil level and top up if necessary, following the instructions given in the chapter on CONTROLS AND MAINTENANCE.

If the condition persists, contact an Authorised Service Centre.

Fuel circuit

Avoid using the engine with only a small reserve of fuel in the fuel tank; this encourages the formation of condensation and makes it more likely you will suck up dirt or air, resulting in engine stoppage.

CAUTION!



When refuelling, always pay great care to ensure that no solid or liquid pollutants enter the fuel tank; you must also remember that smoking and live flames are prohibited when refuelling.

CAUTION!



Never loosen the circuit connectors in any way.

Air intake and exhaust discharge circuits

Inspect the cleanliness of the air intake circuit on a regular basis. The maintenance intervals indicated in this manual vary according to the conditions in which the engine is used.

In particularly dusty environments it is necessary to carry out maintenance at more frequent intervals; with respect to the indications provided in the chapter CONTROLS AND MAINTENANCE.

CAUTION!



Visually check that the exhaust circuit is not blocked or damaged, so as to prevent dangerous fumes.

Electrical starter system

Periodically check, particularly during the winter, to ensure that the batteries are clean and in full working order, checking and topping up as indicated in the chapter CONTROLS AND MAINTENANCE. Should it be necessary to replace the batteries, always respect the capacity and minimum discharge current intensity requirements.

CAUTION!



The batteries contain an acid solution that will burn the skin and corrode clothing; when checking them, always wear protective clothing, gloves and goggles, do not smoke or use live flames in the vicinity, and make sure that the room they are housed in is adequately ventilated.

RUNNING IN

Thanks to modern engine construction technology, no particular running in procedure is required. However, it is recommended that, for the first 50 hours, you do not use the engine at high power for long periods.

REFUELLING

Parts to be supplied	N45 ... NEF 45 ... litres (kg)	N67 ... NEF 67 ... litres (kg)
Cooling circuit ⁽¹⁾	8.5	10.5
Lubrication circuit ⁽²⁾ total capacity ⁽³⁾	12.8 (11.8)	17.2 (15.8)
Periodic changing: oil sump at minimum level	7 (6.5)	8.7 (8)
oil sump at maximum level	11.5 (10.5)	15.2 (14)
Fuel tank ⁽⁴⁾	-	-

NOTE: the amounts indicated relate to the standard configuration of the engine only.

- (1) Use a mixture of water and 50% PARAFU 11 even during the summer months. As an alternative to PARAFU 11, use another product that complies with international specifications SAE J 1034.
- (2) Use lubricants that comply with international specifications ACEA E3 - E5 (high power engines), API CF - CH4 (associated with fuels with a percentage sulphur < 0.5%), MIL - L - 2104 F.

The viscosity level of oil to be used depending on surrounding temperatures is given in the table provided in the appendix.

Oil consumption is considered acceptable when it reaches a maximum of 0.5% of fuel consumption

- (3) The amounts indicated refer to initial refuelling, and include filling the engine, sump and filter.
- (4) Only use normal commercial diesel fuel (EN590 standards). Do not use additives. Do not use fuels derived from the synthesis of organic substances and vegetable oils (Biodiesel).

WARNING

Refuelling from drums or tanks may result in pollution of the diesel fuel, with the risk of damage to the injection system; if necessary, filter the fuel in a suitable manner or allow sedimentation of the impurities before refuelling.



Low temperature diesel

EN590 specifications distinguish different classes of diesel fuel, identifying the characteristics of those best suited to low temperatures. It is entirely up to the Oil companies to comply with these regulations, which foresee that fuels suited to the climatic and geographic conditions of the various Countries be distributed.

■ CONTROLS AND MAINTENANCE

MAINTENANCE PERSONNEL

The engine control and maintenance operations described in the following chapter require training, experience and compliance with current safety regulations; for this reason they must be carried out by special technicians, as indicated below.

- ❑ **Controls:** by workshop technicians or the machine user if necessary.
- ❑ **Periodic maintenance:** by qualified personnel equipped with suitable equipment and adequate means of protection. Operations marked by the key symbol (see illustration). 
- ❑ **Special maintenance:** by qualified Authorised Service Centre staff with specific technical information and equipment. Operations marked by the key symbol (see illustration). 

The Authorised Service Centres are the ones in the IVECO MOTORS Technical Service Network.

ACCIDENT PREVENTION

- ❑ Always wear heavy-duty footwear and overalls.
- ❑ Never wear loose, flapping garments, rings, bracelets and/or necklaces in the vicinity of engines or moving parts.
- ❑ Always wear protective gloves and goggles when:

- filling up batteries with acid solution
- refuelling with inhibitors or antifreeze
- replacing or topping up lubricant (hot engine oil may cause burns and scalds. Only carry out these operations when the oil has dropped to a temperature of below 50°C).
- ❑ When working in the engine compartment, pay particular attention to how you move, to avoid contact with moving parts or high temperature components.
- ❑ Wear goggles and use high pressure air jets (maximum air pressure used to clean is 200 kPa (2 bar, 30 psi, 2 kg/cm²).
- ❑ Wear a protective helmet when working in an area where there are suspended loads or systems installed at head-height.
- ❑ Use protective hand cremes.
- ❑ Immediately replace wet overalls.
- ❑ Always keep the engine clean, removing oil, grease and coolant stains.
- ❑ Store cloths in flame-proof containers.
- ❑ Do not leave foreign bodies on the engine.
- ❑ Use suitable, safe containers for used oil.
- ❑ When completing a repair, make suitable provisions to stop the engine taking in air if, after start-up, an uncontrolled increase in engine speed were to occur.

CAUTION!



Do not carry out maintenance operations when the electric power supply is turned on: always check to ensure that the appliances are properly earthed. During diagnosis and maintenance operations, make sure that your hands and feet are dry, and whenever possible use insulating

stands.

FREQUENCY

Controls (when in use)	Frequency
Check oil level in engine	Daily
Check coolant level	Daily
Clean heat exchangers	Daily
Clean air filter	Daily
Drain water from the fuel pre-filter	150 hours ⁽¹⁾
Check/top up electrolyte level in batteries and clean terminals	Half-yearly

The maintenance intervals indicated below take into account the typical working factors for various types of engine use; the most suitable interval for maintenance operations for the various applications will be indicated by the maintenance staff, according to the way and working conditions in which the engine is used.



Planned maintenance

Frequency

Check state and tension of belt	300 hours ⁽²⁾
Change oil	600 hours ^{(3) (4)}
Change oil filter/s	600 hours ^{(3) (4) (5)}
Change fuel filter/s	600 hours ^{(3) (1) (5)}
Change fuel pre-filter	600 hours ^{(3) (1)}
Check exhaust pipe/s for damage	Half-yearly
Drain/suck water and condensation from fuel tank	Half-yearly ⁽¹⁾
Change auxiliary member belt	1200 hours
Change air filter	1200 hours ⁽⁶⁾
Change coolant	1200 hours or 2 years



Special maintenance

Frequency

Clean the turbocharger	1200 hours ⁽⁷⁾
Check the efficiency of the pre-post heating system (if there is one)	1200 hours
Injector calibration	1800 hours
Overhaul injection pump	3000 hours
Adjust play in valves-rocker arms	3000 hours

- 1) Maximum period when using good quality fuel, (EN 590 standard); this is reduced if the fuel is contaminated and alarms are triggered due to blockage of the filters and presence of water in the pre-filter. When blockage of the filter is indicated, it must be replaced. If the water in pre-filter indicator does not go out after drainage, the pre-filter must be replaced.
- 2) Refers to engines with traditional and automatic tensioning devices
- 3) Must be performed annually, even if the required number of working hours are not reached
- 4) Replace lubricants according to the frequency indicated in the REFUELLING table.
- 5) Only use filters with the following characteristics:
 - filtration level $< 12 \mu\text{m}$
 - filtering efficiency $\beta > 200$.

- 6) The frequency with which operations are carried out will depend on the working conditions and efficiency/wear of the product.
- 7) Required by oil vapour recirculation.

REQUIREMENTS

1. Do not disconnect the batteries with the engine running.
2. Do not carry out arc welding operations in the vicinity of the engine without first removing electrical cables.
3. After each maintenance operation involving disconnection of the battery/batteries, make sure that the terminals have been properly locked onto the poles.
4. Do not use battery chargers to start the engine.
5. Disconnect the on-board network battery/batteries when recharging.
6. Do not paint the appliances, components and electrical connectors equipping the engine.
7. Disconnect the battery/batteries before any electrical operations.
8. Contact the Manufacturer before installing electronic equipment on board (two-way radios and the like).

HOW TO PROCEED

Check oil level in engine

Only proceed with the engine stopped and at a low temperature, so as to avoid the risk of burning.

- ❑ Take all necessary action to ensure that the machine is "level".
- ❑ Using the dipstick (1), check that the oil level is between the "Min" and "Max" levels.
- ❑ If the level is too low, top up through the inlet, after first removing the relevant cap (2).

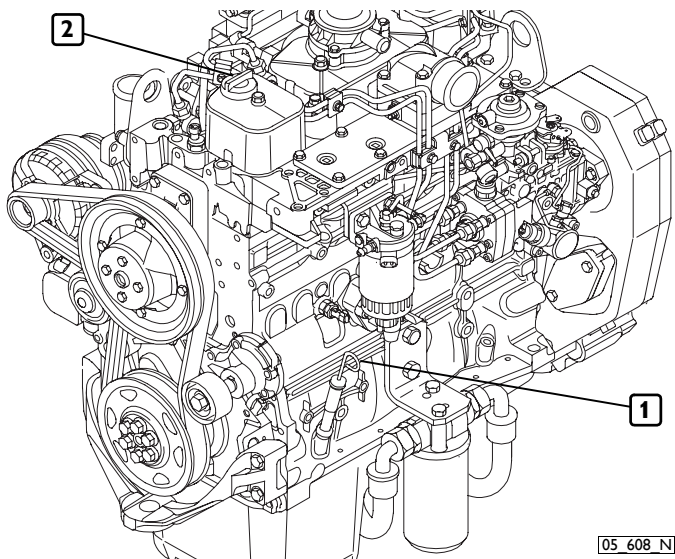

05 608 N

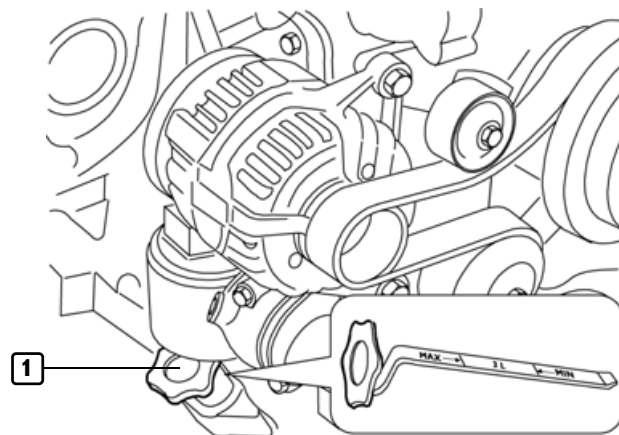

05 584 N

WARNING

- ❑ After topping up, make sure that the oil level does not exceed the "Max" limit marked on the dipstick.
- ❑ Make sure that the dipstick is inserted properly and the filler cap is turned in a clockwise direction until it stops turning completely.

Check coolant level

Only proceed with the engine stopped and at a low temperature, so as to avoid the risk of burning.

- ❑ With the engine cold, make sure that the level of coolant in the expansion tank is above the minimum level.
- ❑ Visually check that the fluid level is not more than $\frac{2}{3}$ of the height of the tank, to allow the increase in temperature to increase the volume of fluid.
- ❑ Top up the tank if necessary, using clean water. Do not use distilled water; indications are provided in the table REFUELLING.

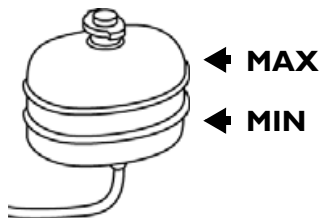

05_585_N

CAUTION



When the engine is warm, a pressure liable to cause hot liquid to be expelled with extreme violence is created within the cooling circuits. This results in a danger of burning.

Clean heat exchangers

Check that the radiator air inlets are free from dirt (dust, mud, straw, etc.).

Clean them if necessary, using compressed air or steam.

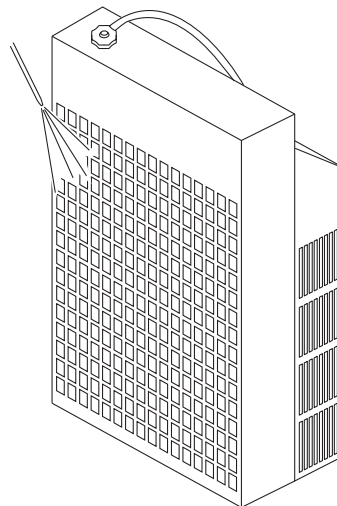

05_609_N

CAUTION



The use of compressed air makes it necessary to use suitable protective equipment for the hands, face and eyes. Please see the prescriptions in the paragraph on ACCIDENT PREVENTION.

Cleaning the air filter

(Refers to IVECO MOTORS components)

Only proceed with the engine stopped.

- ❑ Remove the filter cover (1) after first unscrewing the locking handle.
- ❑ Remove the external cartridge (2), after unfastening the second locking handle; during this operation, take care to ensure that no dust get into the sleeve.
- ❑ Check that there is no dirt. If there is, clean the filter element as indicated below.
- ❑ Blow dehumidified compressed air through the filter element, from the inside outward (maximum pressure 200 kPa). Do not use detergents; do not use diesel.
- ❑ Never use tools to beat the filter element, and check its condition before replacing it.
- ❑ Replace the filter if any breakages or tears are found.
- ❑ Check that the gasket at its base is in good condition. Some filter systems are fitted with a second filter element (3) which does not require cleaning; this must be replaced at least once every 3 changes in the main element.
- ❑ Reassemble by repeating the above operations in reverse order.
- ❑ Set up the mechanical blockage indicator for operation by pressing the button located on the top part of the indicator. This operation is not necessary if there is an electrical sensor.

WARNING

Take care to ensure that the parts are reassembled correctly. Imperfect assembly might result in unfiltered air being sucked into the engine, causing serious damage.

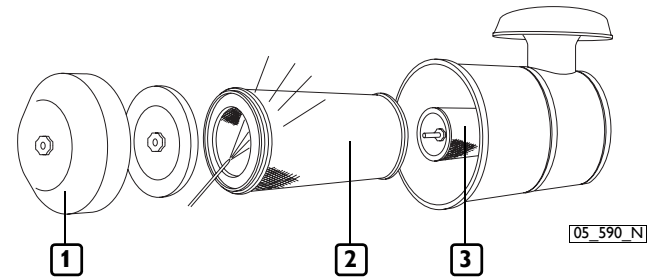

Drain water from the fuel pre-filter

The high risk of refuelling with fuel that is polluted by foreign bodies and water makes it advisable to carry out this control every time you refuel.

Proceed with the engine stopped.

- Place a container under the filter or pre-filter to collect the fluid.
- Unscrew the tap plug (1) in the bottom part of the filter; in some lay-outs the plug includes a sensor to detect the presence of water in the diesel.
- Drain off liquid until only "diesel" can be seen.
- Close the plug again, tightening it completely by hand.
- Dispose of the drained fluids according to current requirements.

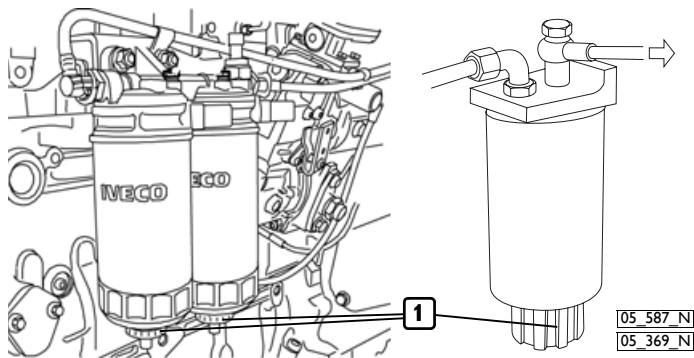

Check/top up electrolyte level in batteries

Place the batteries on a level surface, then proceed as follows.

- Visually check that the fluid level is between the "Min" and "Max" limits; in the absence of references, check that the fluid covers the Lead plates inside the elements.
- Top up with distilled water only those elements in which the level is below the minimum.
- Contact specialised technical staff if the battery needs recharging.
- Have the efficiency of the battery recharging system tested if a voltage of less than 11 V (for 12 V rated systems) or 22 V (for 24 V rated systems) is detected with the engine running.
- On this occasion, make sure that the terminals and clamps are clean, properly locked and protected by vaseline.

CAUTION



- The batteries contain sulphuric acid, which is extremely caustic and corrosive; always wear protective gloves and goggles when topping them up. Whenever possible it is recommended that this control be carried out by specialised personnel.*
- Do not smoke or use live flames near the batteries during the control, and make sure that the room you are working in is adequately ventilated.*

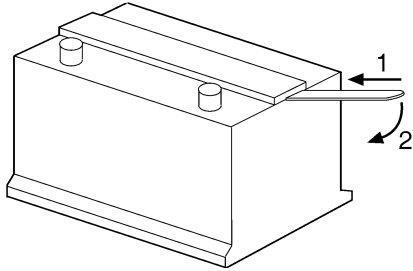

04_362_N

Some types of battery have a single cover for all the inspection plugs. To access the elements, use a lever as shown in the figure.

Restore the correct tension in the auxiliary member drive belt

(Refers to engines with traditional tensioning devices)

- Loosen the screw fixing the alternator to the bracket (1).
- Loosen the bolt anchoring the alternator to its lower support.
- Proceed to tighten the tensioner (2), locking the counternut.
- On reaching the required tension, lock the fixing screws and bolt.

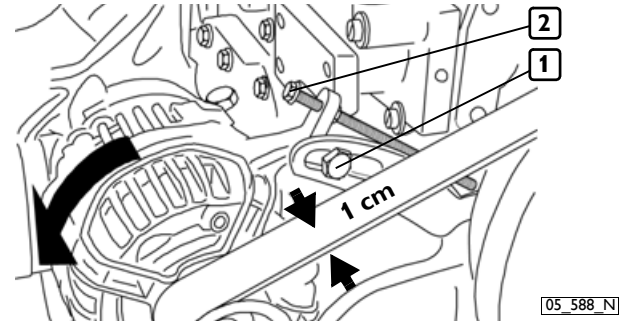

05_588_N

For engines without a screw tensioner, proceed after loosening the fixing screws (1) and anchor bolt, turning the alternator as shown in the figure until the required tension is reached, after which tighten the fixing screws and anchor bolt firmly.

WARNING

Replace the belt if any abrasion, cracking or tearing is seen, and if oil or fuel has spilled onto the belt.

Change oil

Only proceed with the engine stopped and at a low temperature, so as to avoid the risk of burning.

- ❑ Place a container under the drainage plug to collect the used oil (see illustrations in the chapter ENGINE TECHNICAL DATA).
- ❑ Unscrew the plug and wait until the sump has emptied completely, then fasten the plug in place again.
- ❑ Fill up through the feeder hole (1) on the timer cover or elsewhere (opt.), using the types and amounts of oil indicated in the table REFUELLING.
- ❑ Using the dipstick (2), check that the oil level is between the "Min" and "Max" levels.
- ❑ Dispose of used oil according to current requirements.

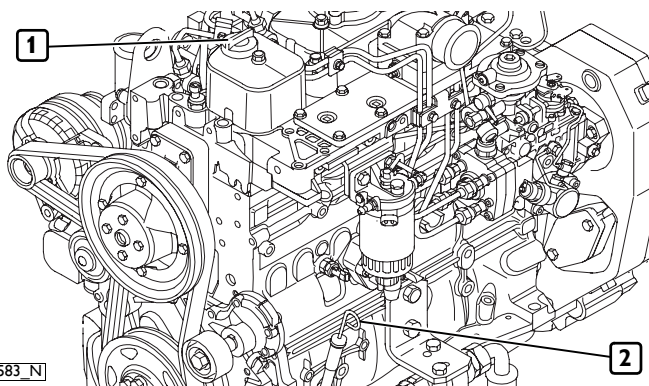

05_583 N

Change oil filter

Only proceed with the engine stopped and at a low temperature, so as to avoid the risk of burning.

Only use filters with a filtration level equivalent to the ones you are replacing (see section FREQUENCY).

- ❑ Place a container under the filter support (1), to collect the used oil.
- ❑ Unscrew the filter and remove it (2).
- ❑ Carefully clean the surfaces of the support that are in contact with the seal gasket.
- ❑ Damp the new seal gasket with a thin layer of oil.
- ❑ Hand screw the new filter into place until the seal gasket touches the support, then lock by a further 3/4 of a turn.
- ❑ Dispose of the old filter according to current requirements.

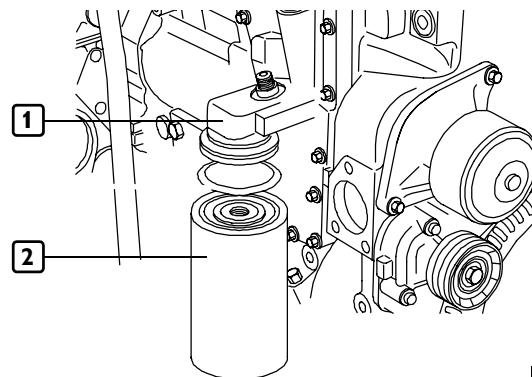

05_610 N

Change fuel filter/s

Only proceed with the engine stopped and at a low temperature, so as to avoid the risk of burning.

Only use filters with a filtration level equivalent to the ones you are replacing (see section FREQUENCY).

- ❑ Remove the filter/s (1) by unscrewing it.
- ❑ Check that the new filter has performance levels that satisfy the needs of the engine (e.g. by comparing them with the old one).
- ❑ Damp the new filter seal with diesel or engine oil.
- ❑ Hand screw the new filter into place until the seal gasket touches the support, then lock by a further 3/4 of a turn.
- ❑ Pay particular attention to the electrical fuel pre-heater and relevant electrical connection (1).

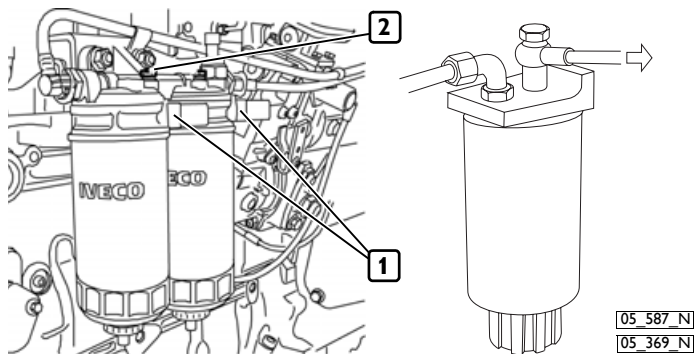

WARNING

Do not fill up the new filter before it is fitted to the support, to avoid inserting harmful impurities into the injection system and circuit.

Bleeding procedure:

- ❑ Loosen the fuel outlet manifold, located on the upper part of the filter (2).
- ❑ Make sure that any diesel coming out will not dirty the auxiliary member drive belt or be dispersed into the environment.
- ❑ Use the pre-filter hand pump until the diesel coming out is free from any residual air, or perform the same operation using the hand pump (see section ENGINE TECHNICAL DATA).
- ❑ Lock the manifold loosened as above to the required torque.
- ❑ Dispose of any diesel expelled during the above operation.
- ❑ Start the engine and run it at minimum speed for a few minutes to eliminate any residual air.

NOTE: should it be necessary to accelerate the bleeding phase, the hand pump can be used during start-up.

Changing the fuel pre-filter

Only proceed with the engine stopped.

- ❑ Remove the pre-filter by unscrewing it.
- ❑ Check that the new filter has performance levels that satisfy the needs of the engine (e.g. by comparing them with the old one).
- ❑ Damp the new filter seal with diesel or engine oil.
- ❑ Hand screw the new filter into place until the seal gasket touches the support, then lock by a further 3/4 of a turn.
- ❑ Loosen the bleeder screw (2) on the pre-filter support and activate the hand pump (1) until the supply circuit is full. Ensure that any fuel coming out is not dispersed into the environment.
- ❑ Lock the bleeder screw tightly.
- ❑ Start the engine and run it at minimum speed for a few minutes to eliminate any residual air.

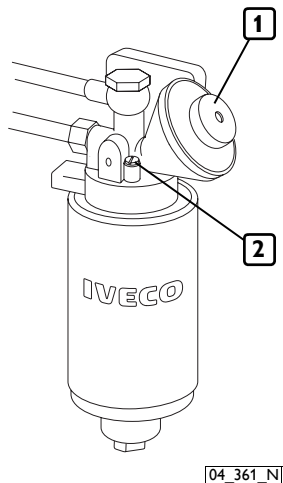

NOTE: should it be necessary to accelerate the bleeding phase, the hand pump can be used during start-up.

Check exhaust pipe/s for damage

Visually check that the exhaust system is not blocked or damaged.

- ❑ Make sure that there is no risk of dangerous fumes within the machine. Contact the Manufacturer if necessary.

Change auxiliary member belt

Please refer to the information provided for checking the belt tension.

Change coolant

Only proceed with the engine stopped and at a low temperature, so as to avoid the risk of burning.

- ❑ Provide suitable containers to ensure that no coolant is dispersed into the environment.
- ❑ Loosen the seal elements, remove the sleeves connecting the engine circuit to the heat exchanger and wait until it has emptied completely. When empty, repair the circuit making sure that the sleeves are perfectly sealed.
- ❑ Fill up the circuit as indicated in the table REFUELLING.
- ❑ Bleed the circuit and top-up if necessary.



WARNING

The operations listed below must only be carried out by qualified staff from the IVECO MOTORS Service Centres or by the Manufacturer's staff.

The methods used to perform them are described in the Technical and Repair Manuals.

Drain/suck condensation from fuel tank

Clean the turbocharger

Check the efficiency of the pre-post heating system

Adjust play in valves-rocker arms

Injector calibration

Overhaul injection pump

MOVING THE ENGINE

The operations necessary to disconnect and subsequently reconnect the engine must only be carried out by technicians from Authorised Service Centres.

When lifting the engine only, use the U-bolts indicated in this manual in the section ENGINE TECHNICAL DATA and marked on the engine with special stickers.

Lifting must be carried out using a rocker arm that keeps the metal cables supporting the engine parallel, using all the U-bolts provided simultaneously; the use of a single U-bolt only is not allowed.

The engine lifting system must have a capacity and size suited to the weight and dimensions of the engine; check that there is no interference between the lifting system and the engine components.

Do not lift the engine before removing the transmission members that are coupled to it.

DISPOSAL OF WASTE

The engine is made up of parts and elements that, if discarded, may cause damage to the environment.

The materials listed below must be handed over to specialised Collection Centres; the laws in force in the various Countries foresee severe penalties for transgressors:

- Starter batteries.
- Used lubricants.
- Mixtures of water and antifreeze.
- Filters.
- Additional cleaning materials (e.g. greasy or fuel-soaked cloths).

■ LONG PERIODS OF INACTIVITY

PREPARING THE ENGINE FOR A LONG PERIOD OF INACTIVITY

In order to prevent oxidation of the internal parts of the engine and of certain components in the injection system, when the engine is expected to be inoperative for periods of more than two months, the following operations must be carried out in preparation for this:

1. Drain the lubricant from the sump, after first warming up the engine.
2. Fill the engine with protective oil type 30/M (or alternatively oil that complies with MIL 2160B type 2 specifications), up to the "minimum" level indicated on the dipstick. Start the engine and keep it running for approximately 5 minutes.
3. Drain the fuel from the injection circuit, from the filter and from the injection pump pipes.
4. Connect the fuel circuit to a tank containing CFB (ISO 4113) protective fluid, and feed in the fluid by putting the circuit under pressure and running the engine for approximately 2 minutes, after first disabling the injection system. This operation can be performed by polarising terminal 50 of the starter motor with a positive voltage equivalent to the rated voltage of the system, using a conductor provided for that purpose.
5. Nebulise approximately 80 g of 30/M protective oil (10 g per litre displacement) into the turbocharger suction inlet, during the pressurised filling operation described in the previous point.
6. Close all the suction, delivery, ventilation and bleeder openings in the engine with suitable plugs, or seal them with adhesive tape.

7. Drain the residual 30/M protective oil from the sump. This oil can be used again for a further 2 preparation operations.
8. Fit signs reading "ENGINE WITHOUT OIL" to the engine and to the on-board control panel.
9. Drain the coolant, if it has not been mixed with suitable antifreeze and corrosion inhibitors, and affix a sign to indicate the fact.

In the event of prolonged inactivity, the operations described must be repeated every 6 months, following the procedure given below:

- A) drain the 30/M protective oil from the sump;
- B) repeat the operations described from point 2 to point 7.

Should you intend to protect external parts of the engine, proceed by spraying OVER 19 AR protective liquid on unpainted metal parts, such as the flywheel, pulleys and the like, avoiding belts, connector cables and electrical equipment.

RESTARTING THE ENGINE AFTER A LONG PERIOD OF INACTIVITY

1. Drain the residual 30/M protective oil from the sump.
2. Fill the engine, as prescribed, with lubricant of the type and amount indicated in the table REFUELLING.
3. Drain the CFB protective fluid from the fuel circuit, carrying out this operation as indicated under point 3. of PREPARING THE ENGINE FOR A LONG PERIOD OF INACTIVITY.
4. Remove the plugs and/or seals from the suction, delivery, ventilation and bleeder openings in the engine, restoring it to a normal state of use. Connect the turbocharger suction inlet to the air filter.
5. Connect the fuel circuits to the machine's fuel tank, completing the operations as indicated in point 4. of PREPARING THE ENGINE FOR A LONG PERIOD OF INACTIVITY. During filling operations, connect the fuel return pipe to a collection tank, so as to prevent any residual CFB protective fluid from flowing into the machine's fuel tank.
6. Check the engine and fill it up with coolant as prescribed, bleeding it if necessary.
7. Start the engine and keep it running until the idling speed rate has stabilised completely.
8. Check that the instruments on the on-board control panel/s are showing plausible values, and that no alarms are shown.
9. Stop the engine.
10. Remove the "ENGINE WITHOUT OIL" signs from the engine and from the on-board control panel.

■ BEHAVIOUR IN AN EMERGENCY

The user of a machine that has been constructed according to safety regulations, when following the instructions provided in this manual and the indications given on the engine labels, will be working in safe conditions.

Should improper conduct result in accidents, always request the intervention of trained first aid specialists immediately.

In an emergency and while awaiting the arrival of first aid specialists, follow the instructions given below.

Engine malfunctions

When operating with a malfunctioning engine, take the greatest possible care when manoeuvring and make sure that all those aboard are holding firmly to safe hand-holds (see section on ENGINE MALFUNCTIONS)

In case of fire

Extinguish the fire using the fire-fighting equipment foreseen, and in the manner indicated by Fire prevention authorities (fire-fighting equipment for certain machines and equipment is compulsory under current safety legislation).

Burns and scalds

1. Extinguish any flames on the burned person's clothing, by:
 - throwing water over them;
 - using a powder fire-extinguisher, without directing the jet at the person's face;

- covering with blankets or rolling the victim on the ground.
2. Do not attempt to remove pieces of clothing that may have stuck to the skin;
 3. In the case of scalding, immediately but carefully remove any clothing that may be soaked in the hot liquid;
 4. Cover the burn with a special burn dressing or sterile bandage.

Carbon monoxide intoxication (CO)

Carbon monoxide from the engine exhaust is without smell, and is dangerous both because it causes intoxication, and because when combined with air it forms an explosive mixture.

In closed rooms, carbon monoxide is extremely dangerous, as it can reach critical concentrations within a very short time.

When assisting an intoxicated person in a closed room:

1. Ventilate the room immediately, to reduce the concentration of gas.
2. When entering the room, hold your breath, do not light flames, lights or ring electric doorbells or phones, to avoid the risk of explosion.
3. Carry the intoxicated person out into the fresh air or into a well ventilated room, resting him on one side if he is unconscious.

Electrocution

- A.** The engine's electrical 12 V or 24 V electrical system does not involve the risk of electrocution, however, in the event of a short-circuit caused, for example, by a metal tool, there is a risk of burning due to overheating of the object through which the electrical current runs. In these circumstances:
1. Remove the object that caused the short-circuit, using means that provide sufficient heat insulation.
 2. Switch off the power at the main switch, if there is one.
- B.** The electric generator systems (generator units) normally produce high voltages that are liable to result in extremely dangerous current levels. In the event of medium or high voltage electrocution:
1. Turn off the power supply at the main switch before touching the victim. If this is not possible, use equipment that is both safe and adequately insulated when touching the victim; remember that touching a victim of electrocution is also extremely dangerous for the person giving aid.
 2. Proceed as indicated by the competent authorities (cardiac massage, mouth-to-mouth resuscitation, etc...)

Injuries and fractures

The vast number of possible circumstances and the specific nature of operations required means that the intervention of a medical team is necessary.

1. In the event of bleeding, keep the edges of the wound pressed together until help arrives.
2. If there is any suspicion of a fracture, do not move the injured part and only move the patient if absolutely necessary.

Caustic burns

Caustic skin burns are caused by contact with extremely acid or alkaline substances.

For electric maintenance technicians these are typically caused by acid from batteries; in these circumstances, proceed as follows:

1. Remove any clothing soaked in the caustic substance.
2. Wash the area with lots of running water, avoiding parts that have not been burned.

If either battery acid, lubricants or diesel come into contact with the eyes: wash the eyes with water for at least 20 minutes, keeping the eyelids open so that the water flows over the eyeball (move the eye in all directions to wash more thoroughly).

