

# **CURSOR SERIES**

**Industrial application**

**C13**

**C13 ENT**

This publication describes the characteristics, data and correct methods for repair operations on each component of the vehicle.

If the instructions provided are followed and the specified equipment is used, correct repair operations in the programmed time will be ensured, safeguarding against possible accidents.

Before starting to perform whatever type of repair, ensure that all accident prevention equipment is available and efficient.

All protections specified by safety regulations, i.e.: goggles, helmet, gloves, boot, etc. must be checked and worn.

All machining, lifting and conveying equipment should be inspected before use.

The data contained in this publication was correct at the time of going to press but due to possible modifications made by the Manufacturer for reasons of a technical or commercial nature or for adaptation to the legal requirements of the different countries, some changes may have occurred.

No part of this publication, including the pictures, may be reproduced in any form or by any means.

Publication edited by  
Iveco Motors  
Iveco SpA  
PowerTrain  
Mkt. Advertising & Promotion  
Viale dell'Industria, 15/17  
20010 Pregnana Milanese  
Milano (Italy)  
Print **P2D32C001GB/W** - 1<sup>st</sup> Ed. 11.2004  
**C13 ENT Series**

Produced by:











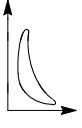
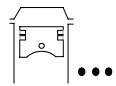
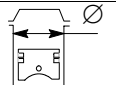
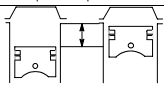
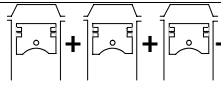
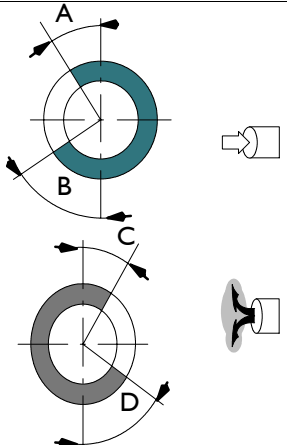
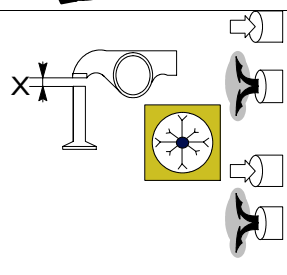
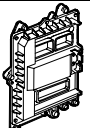
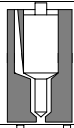
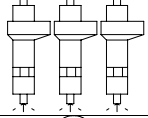
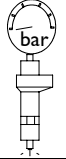

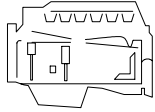
B.U. TECHNICAL PUBLISHING  
Iveco Technical Publications  
Lungo Stura Lazio, 15/19  
10156 Turin - Italy

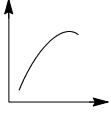
**CORRESPONDENCE BETWEEN TECHNICAL CODE AND COMMERCIAL CODE**

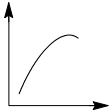
Technical Code	Commercial Code
F3BE0687A*...	C13 ENT

## SPECIFICATIONS

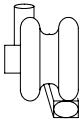
	Type	<b>C13 ENT SERIES</b>	
	Cycle	4-stroke Diesel engine	
	Fuel feed	Turbocharged	
	Injection	Direct	
	No. of cylinders	6 in line	
	Bore	mm	135
	Stroke	mm	150
	Total displacement	cm <sup>3</sup>	12880
	VALVE TIMING		
	opens before T.D.C.	A	17°
	closes after B.D.C.	B	30°
	opens before B.D.C.	D	50°
	closes after T.D.C.	C	9°
	For timing check	X	mm
			mm
	Running	X	mm
			mm
			0.35 to 0.45
			0.45 to 0.55
	FEED	Through fuel pump - filters	
	Injection type: Bosch	With electronically regulated injectors PDE 31 pump injectors controlled by overhead camshaft MS6.2DC7 ECU	
	Nozzle type	-	
	Injection order	1 - 4 - 2 - 6 - 3 - 5	
	Injection pressure	bar	1500
	Injector calibration	bar	290 ± 12









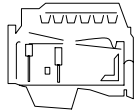
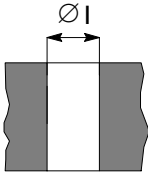
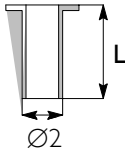

C13 ENT Series engines		TECHNICAL CODE
	Type	F3BE0687A*...
	Compression ratio	16.5 ± 0.8
 	Max. output	kW (HP) rpm
		368 (500) 1900
 	Max. torque	Nm (kgm) rpm
		2250 (225) 1200
	Loadless engine idling	rpm
		-
	Loadless engine peak	rpm
		-
	Bore x stroke Displacement	mm cm <sup>3</sup>
		135 x 150 12880
	<b>SUPERCHARGING</b>	Intercooler Direct injection
	Turbocharger type	HOLSET HX60W
 	<b>LUBRICATION</b>	Forced by gear pump, relief valve single action oil filter
	Oil pressure (warm engine)	
	- idling	bar
	- peak rpm	bar
		4 5
	<b>COOLING</b>	Liquid
	Water pump control	Through belt
	<b>Thermostat</b>	
	- start of opening	°C
		80



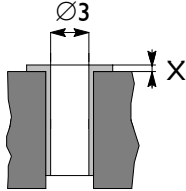
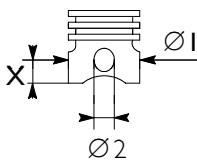



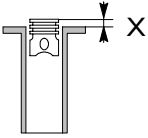
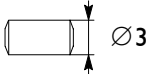



Data, features and performances are valid only if the technician fully complies with all the installation requirements provided by Iveco Motors.

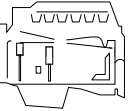
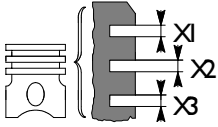
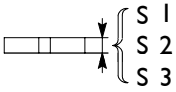



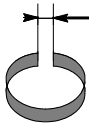
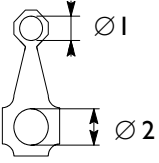
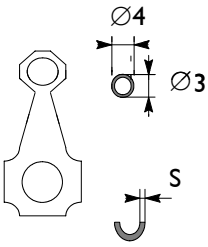

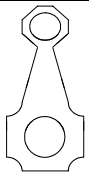

Furthermore, the use of the unit after overhaul should conform to the original specified power and engine rev/min for which the engine has been designed.

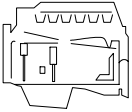
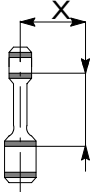
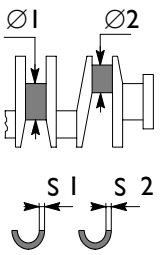
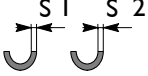
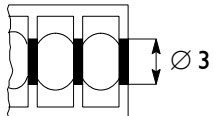
**ASSEMBLY CLEARANCE DATA**

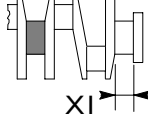
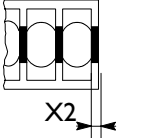
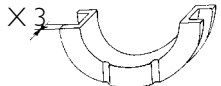
 Type	<b>C13 ENT SERIES</b>	
<b>CYLINDER BLOCK AND CRANKMECHANISM COMPONENTS</b>	mm	
 Bores for cylinder liners: $\varnothing 1$	upper lower	153.500 to 153.525 152.000 to 152.025
 Cylinder liners: external diameter: $\varnothing 2$ length L	upper lower L	153.461 to 153.486 151.890 to 151.915 -
 Cylinder liners - crankcase bores	upper lower	0.014 to 0.039 0.085 to 0.135
  > External diameter	$\varnothing 2$	-
 Cylinder sleeve inside diameter $\varnothing 3A^*$ inside diameter $\varnothing 3B^*$ Protrusion X	$\varnothing 3A^*$ $\varnothing 3B^*$ X	135.000 to 135.013 135.011 to 135.024 0.045 to 0.075
* Selection class * Under a load of 800 N		
 Pistons: measuring dimension external diameter $\varnothing 1A^*$ external diameter $\varnothing 1B^*$ pin bore $\varnothing 2$	X $\varnothing 1A^*$ $\varnothing 1B^*$ $\varnothing 2$	20 134.881 to 134.893 134.892 to 134.894 54.010 to 54.018
 Piston - cylinder sleeve	A* B*	0.107 to 0.132 0.096 to 0.132
* Selection class		
  < Piston diameter	$\varnothing 1$	-
 Pistons protrusion X	X	0.12 to 0.42
 Gudgeon pin $\varnothing 3$	$\varnothing 3$	53.994 to 54.000
 Gudgeon pin - pin housing		0.010 to 0.024

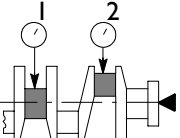









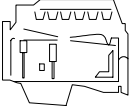
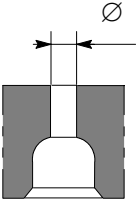
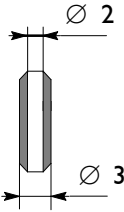



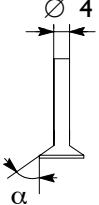

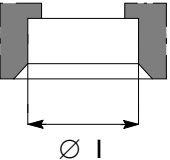

- Class A pistons supplied as spares.
- Class B pistons are fitted in production only and are not supplied as spares.

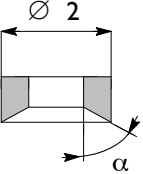

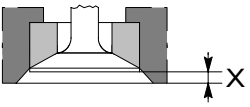

	Type	<b>C13 ENT SERIES</b>	
<b>CYLINDER BLOCK AND CRANKMECHANISM COMPONENTS</b>		mm	
	Piston ring grooves	X1 * X2 X3	3.445 to 3.475 3.05 to 3.07 5.02 to 5.04
* measured on Ø of 130 mm			
	Piston rings: trapezoidal seal lune seal milled scraper ring with slits and internal spring	S1 * S2 S3	2.796 to 2.830 2.970 to 3.000 3.970 to 3.990
* measured on Ø of 130 mm			
	Piston rings - grooves	1 2 3	0.81 to 0.179 0.060 to 0.100 0.030 to 0.070
		>	Piston rings
	Piston ring end gap in cylinder liners	X1 X2 X3	0.40 to 0.55 0.65 to 0.80 0.40 to 0.75
	Small end bush housing nominal Big end bearing housing nominal - Class - Class - Class	Ø1 Ø2 { 1 2 3	59.000 to 59.030 94.000 to 94.030 94.000 to 94.010 94.011 to 94.020 94.021 to 94.030
	Small end bush diameter outside inside Big end bearing shell Red Green Yellow	Ø4 Ø3 S	59.085 to 59.110 54.019 to 54.035 1.965 to 1.975 1.976 to 1.985 1.986 to 1.995
	Small end bush - housing		0.055 to 0.110
	Piston pin - bush		0.019 to 0.041
		>	Big end bearing
	Connecting rod weight		g.
	Class	A B C	4661 to 4694 4695 to 4728 4729 to 4762





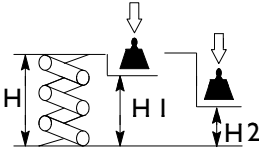
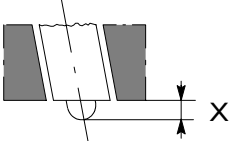
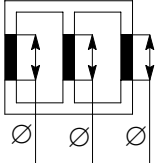
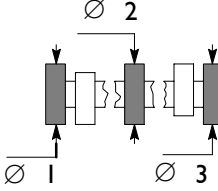
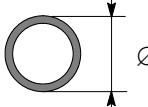



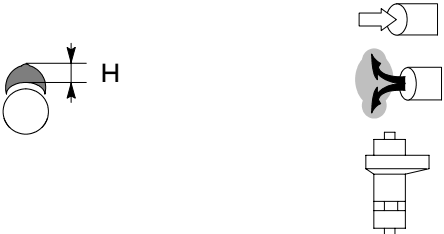
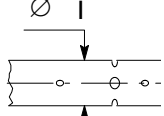

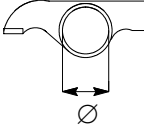

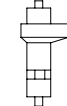
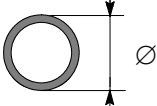

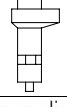
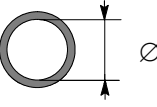
		C13 ENT SERIES	
CYLINDER BLOCK AND CRANKMECHANISM COMPONENTS		mm	
	Measuring dimension	X	125
	Max. connecting rod axis misalignment tolerance	≡	0.08
	Main journals - rated value - class - class - class	Ø1 1 2 3	99.970 to 100.000 99.970 to 99.979 99.980 to 99.989 99.990 to 100.000
	Crankpins - rated value - class - class - class	Ø2 1 2 3	89.970 to 90.000 89.970 to 89.979 89.980 to 89.989 89.990 to 90.000
	Main bearing shells Red Green Yellow*	S1	3.110 to 3.120 3.121 to 3.130 3.131 to 3.140
	Big end bearing shells Red Green Yellow*	S2	1.965 to 1.975 1.976 to 1.985 1.986 to 1.995
	Main bearing housings - rated value - class - class - class	Ø3 1 2 3	106.300 to 106.330 106.300 to 106.309 106.310 to 106.319 106.320 to 106.330
	Bearing shells - main journals		0.060 to 0.100
	Bearing shells - big ends		0.050 to 0.090
	Main bearing shells		0.127 - 2.254 - 0.508
	Big end bearing shells		0.127 - 2.254 - 0.508
	Main journal, thrust bearing	X1	47.95 to 48.00
	Main bearing housing, thrust bearing	X2	40.94 to 40.99
	Thrust washer halves	X3	3.38 to 3.43
	Crankshaft end float		0.10 to 0.30
	Alignment	 1 - 2  1 - 2  1 - 2	≤ 0.025
	Ovalization		0.010
	Taper		0.010

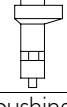
\* Fitted in production only and not supplied as spares

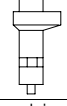

 Type	C13 ENT SERIES	
CYLINDER HEAD - VALVE TRAIN		
mm		
 Valve guide housings in cylinder head	Ø1	15.980 to 15.997
 Valve guide	 Ø2 Ø3	10.015 to 10.030 16.012 to 16.025
 Valve guides - housings in the cylinder heads		0.015 to 0.045
 Valve guide		-
 Valves:	 Ø4 α   Ø4 α	9.960 to 9.975 60° 30' ± 7' 30"  9.960 to 9.975 45° 30' ± 7' 30"
 Valve stem and its guide		0.040 to 0.070
 Valve seat in head	 Ø1   Ø1	49.185 to 49.220  46.985 to 47.020
 Outside diameter of valve seat; angle of valve seat in cylinder head:	 Ø2 α   Ø2 α	49.260 to 49.275 60° - 30'  47.060 to 47.075 45° - 30'
 Recessing of valve	 X   X	0.54 to 0.85  1.75 to 2.05
 Between valve seat and head	 X   X	0.040 to 0.090

 Type	C13 ENT SERIES	
<b>CYLINDER HEAD - VALVE TRAIN</b>	mm	
 Valve spring height: free height H under a load of: 575 ± 28 N H1 1095 ± 54 N H2		72,40 58 45
 Injector protrusion X	X	0.53 to 1.34
 Camshaft bushing housing in the cylinder head: $l \Rightarrow 7$	Ø	88.000 to 88.030
 Camshaft bearing journals: $l \Rightarrow 7$	Ø	82.950 to 82.968
 Outer diameter of camshaft bushings: Ø	Ø	88.153 to 88.183
 Inner diameter of camshaft bushings: Ø	Ø	83.018 to 83.085
 Bushings and housings in the cylinder head		0.123 to 0.183
 Bushings and bearing journals		0.050 to 0.135
Cam lift: 		9.30 9.30 11.216
 Rocker shaft	Ø1	41.984 to 42.000

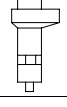
 Type	C13 ENT SERIES
<b>CYLINDER HEAD - VALVE TRAIN</b>	mm
Bushing housing in rocker arms    	45.000 to 45.016 59.000 to 59.019 46.000 to 46.016
Bushing outer diameter for rocker arms    	45.090 to 45.130 59.100 to 59.140 46.066 to 46.091
Bushing inner diameter for rocker arms    	42.025 to 42.041 56.030 to 56.049 42.015 to 42.071
Between bushings and housings    	0.074 to 0.130 0.081 to 0.140 0.050 to 0.091
Between bushings of rocker arms and shaft    	0.025 to 0.057 0.025 to 0.057 0.015 to 0.087
<b>TURBOCHARGER</b> Type End float Radial play	HOLSET HX60W - -

**TOOLS**

TOOL NO.

DESCRIPTION

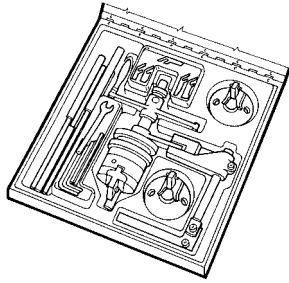
**99305019**

Full-optional tool-kit to rectify valve seat

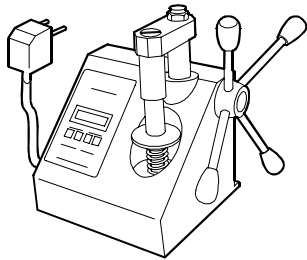
**99305047**

Spring load tester

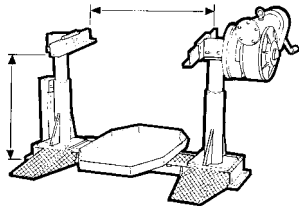
**99322230**

Rotary telescopic stand (range 2000 daN, torque 375 daNm)

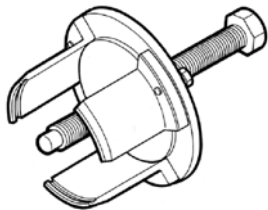
**99340053**

Extractor for crankshaft front gasket

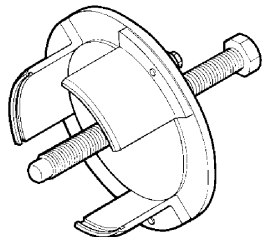
**99340054**

Extractor for crankshaft rear gasket

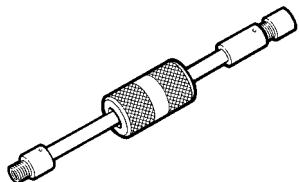
**99340205**

Percussion extractor

**TOOLS**

TOOL NO.	DESCRIPTION
<b>99342149</b>	Extractor for injector-holder
<b>99346250</b>	Tool to install the crankshaft front gasket
<b>99346251</b>	Tool to install the crankshaft rear gasket
<b>99348004</b>	Universal extractor for 5 to 70 mm internal components
<b>99350072</b>	Box wrench for block junction bolts to the underblock
<b>99360143</b>	Box wrench for block junction bolts to the underblock

**TOOLS**

TOOL NO.

DESCRIPTION

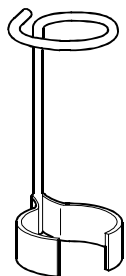
**99360144**

Tools (12 + 6) holding rocker adjustment screw blocks when removing/refitting the rocker shaft

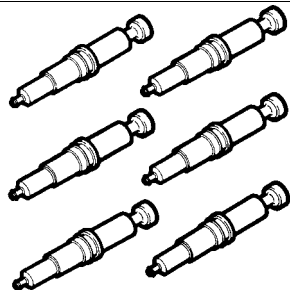
**99360180**

Injector housing protecting plugs (6)

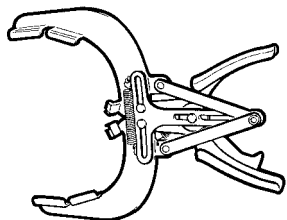
**99360184**

Pliers for assembling and disassembling piston split rings (105-106 mm)

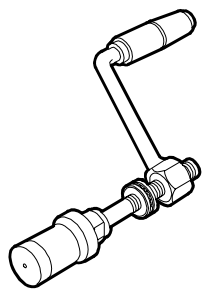
**99360261**

Tool to take down-fit engine valves (to be used with special plates)

**99360262**

Plate for take down-fit engine valves (to be used with 99360261)

**99360296**

Tool to fit back valve guide (to be used with 99360481)

**TOOLS**

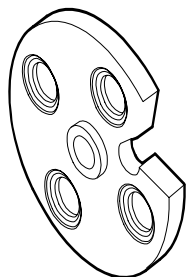
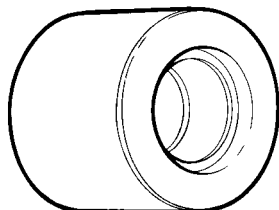
TOOL NO.

DESCRIPTION

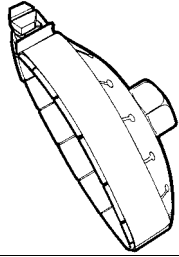
**99360314**

Tool to remove oil filter (engine)

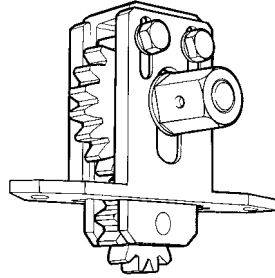
**99360321**

Tool to rotate engine flywheel (to be used with 99360325)

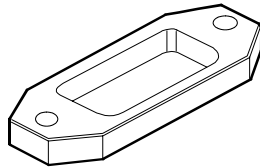
**99360325**

Spacer (to be used with 99360321)

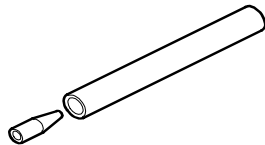
**99360329**

Tool to install gasket on valve guide

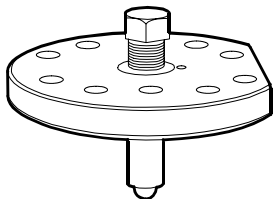
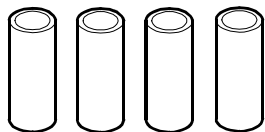
**99360334**Compression tool for checking the protrusion of cylinder liners  
(to be used with 99370415-99395603 and special plates)**99360336**

Spacer (to be used with 99360334)

**TOOLS**

TOOL NO.

DESCRIPTION

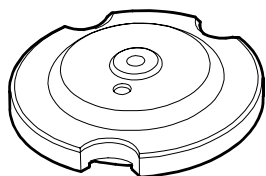
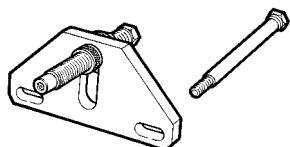
**99360337**Cylinder liner compression plate  
(to be used with 99360334-99360336)**99360351**

Tool to stop engine flywheel

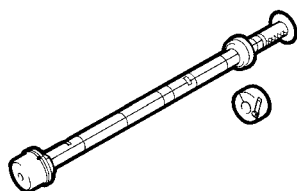
**99360499**

Tool to take down and fit back camshaft bushes

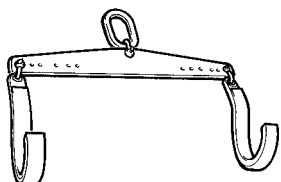
**99360500**

Tool to lift crankshaft

**99360551**

Bracket to take down and fit engine flywheel

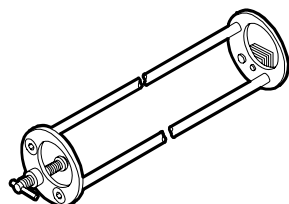
**99360553**

Tool for assembling and installing rocker arm shaft



**TOOLS**

TOOL NO.	DESCRIPTION
<b>99360585</b>	Swing hoist for engine disassembly assembly
<b>99360605</b>	Belt to insert piston in cylinder liner (60 - 125 mm)
<b>99360612</b>	Tool for positioning engine P.M.S.
<b>99360613</b>	Tool for timing of phonic wheel on timing gear
<b>99360703</b>	Tool to stop cylinder liners
<b>99360706</b>	Tool to extract cylinder liners (to be used with specific rings)

**TOOLS**

TOOL NO.

DESCRIPTION

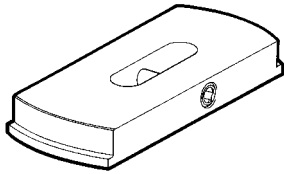
**99360726**

Ring (125 mm) (to be used with 99360706)

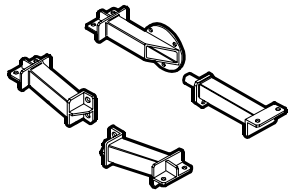
**99361036**

Brackets fixing the engine to rotary stand 99322230

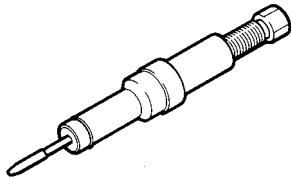
**99365056**

Tool for injector holder heading

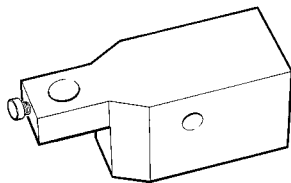
**99370415**

Base supporting the dial gauge for checking cylinder liner protrusion (to be used with 99395603)

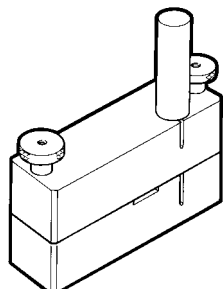
**99378100**

Tool for printing engine identification plates (to be used with special punches)

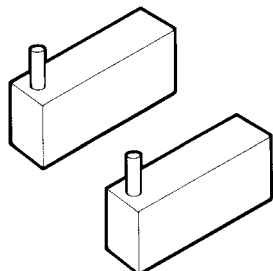
**99378101\***  
**99378103•**  
**99378105■**Punches (**B**) for printing engine identification plates (to be used with 99378100)

**TOOLS**

TOOL NO.	DESCRIPTION
<b>99389834</b>	Torque screwdriver for calibrating the injector solenoid valve connector check nut
<b>99390311</b>	Valve guide sleeker
<b>99390772</b>	Tool for removing injector holding case deposits
<b>99390804</b>	Tool for threading injector holding cases to be extracted (to be used with 99390805)
<b>99390805</b>	Guide bush (to be used with 99390804)
<b>99394015</b>	Guide bush (to be used with 99394041 or 99394043)

**TOOLS**

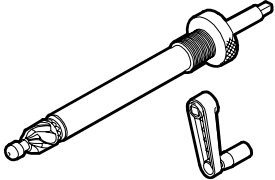
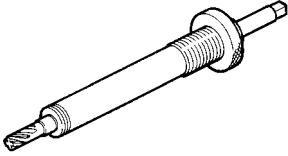
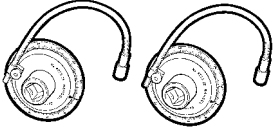
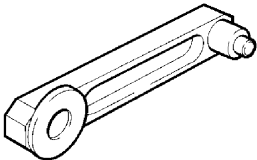
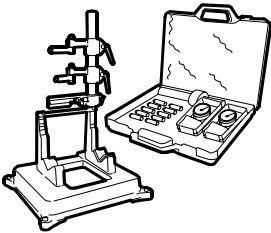
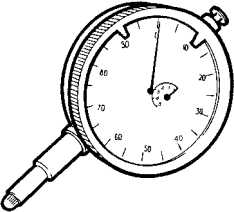
TOOL NO.	DESCRIPTION
<b>99394041</b>	 <p>Cutter to rectify injector holder housing (to be used with 99394015)</p>
<b>99394043</b>	 <p>Reamer to rectify injector holder lower side (to be used with 99394015)</p>
<b>99395216</b>	 <p>Measuring pair for angular tightening with 1/2'' and 3/4'' square couplings</p>
<b>99395218</b>	 <p>Gauge for defining the distance between the centres of camshaft and transmission gear</p>
<b>99395363</b>	 <p>Complete square to check connecting rod squaring</p>
<b>99395603</b>	 <p>Dial gauge (0 - 5 mm)</p>

**TOOLS**

TOOL NO.

DESCRIPTION

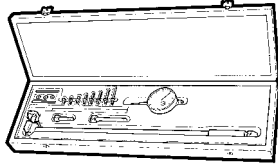
**99395687**

Reaming gauge (50 - 178 mm)

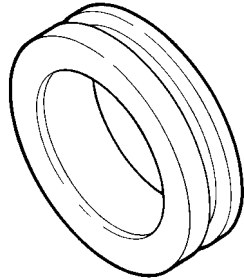
**99396035**

Centering ring of crankshaft front gasket cap

